



to whom it may concern

Please contact

Claudia Meyer

Telephone (direct)

+41 58 58 52 8 72

Telefax (direct)

+41 58 585 63 80

e-mail

claudia.meyer@ch.abb.com

Your ref.

Your letter dated

Our ref. (please quote)

Z-M12/43

Date

2012-06-18

Statement regarding asbestos in our products

We hereby confirm that all our turbochargers as well as their spare parts delivered after 1990 do not contain any asbestous material.

It is, however, possible that turbochargers off VTR...0/1/4 series supplied prior to 1990 may still have core hole cover gaskets; bearing cover gaskets or insulation materials made of asbestos.

Sincerely,

Claudia Meyer
Manager Environment, Health & Safety

Harald Schubert
Head of Management Systems & Quality

ABB Turbo Systems Ltd

Postal address:
ABB Turbo Systems Ltd
P.O. Box
CH-5401 Baden / Switzerland

Tel.: +41 (0)58 685 77 77
Fax: +41 (0)58 685 51 44
e-mail: turbocharging@ch.abb.com
www.abb.com/turbocharging

Business address:
ABB Turbo Systems Ltd
Bruggstrasse 71a
CH-5400 Baden / Switzerland

Credit Suisse
CH-5401 Baden / Switzerland
Account-No.: 111811-21; Clearing-No.: 4835
IBAN: CH31 0483 5011 1811 2100 0

HEAD OFFICE:
14TH FLOOR, SOUTH TOWER,
YURAKUCHO DENKI BLDG.,
1-7-1, YURAKUCHO,
CHIYODA-KU, TOKYO, JAPAN
TEL: +81 3 6860 9081
FAX : +81 3 6860 9083

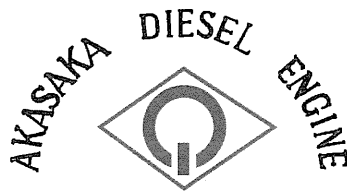

FACTORY:
670-6 YANAGIARAYA,
YAIZU-SHI,
SHIZUOKA PREFECTURE,
JAPAN
TEL: +81 54 685 6080
FAX : +81 54 685 6079

AKASAKA DIESELS LIMITED

関係各位

To whom it may concern

Doc. No. 12 - 009

June 30, 2012

アスベストを含む材料を使用していない旨の宣言書 Asbestos-free Declaration

SOLAS 条約では 2002 年 7 月以降、一部の例外を除きアスベストを含む材料を船舶に新規に搭載することを禁じておりますが、同条約が強化され、2011 年 1 月 1 日からは一切の例外なくアスベストを含む材料の新規搭載が禁止されております。

これを現実的に運用する手段として、IACS(国際船級連合)では、各機器等のメーカーは「アスベストを含む材料を使用していない旨の宣言書 (asbestos-free declaration)」を造船所殿や船舶へ提出するよう求めております。この宣言書は、新造船については 2012 年 7 月 1 日以降に起工される船舶に必要であり、就航船については 2012 年 7 月 1 日以降の定期検査から必要となります。

上記の取決めに基づき、弊社から支給するエンジン、機器、部品、予備品等全ての物品は、アスベストを含む材料を使用していないことをここに宣言いたします。

The SOLAS, which bans new installation of materials (with some exceptions) including asbestos to ships since July 2002, strengthened its regulation to ban installation of all materials including asbestos to ship without any exceptions, since January 1st, 2011.

As a practical measure to put it into effect, IACS (International Association of Classification Societies) is requiring marine equipment manufacturers to submit "Asbestos-free declaration" to shipyards or ship owners. This declaration is to be requested to new ships keel laid on and after July 1st, 2012, and ships in service at the time of periodic inspection on and after July 1st, 2012.

Hence, we, Akasaka Diesels Limited, hereby declare that we do not use any materials including asbestos for our supplies like engine, machinery, components or spare parts etc..

Yours faithfully,

A handwritten signature in black ink, appearing to read "H. Suzuki", is written over a horizontal line.

Hiroshi Suzuki

General Manager

Quality Assurance Group



Supplier's Material Declaration - Asbestos -

Ref.: SD_ALAKK_20120618

Company name: Alfa Laval Aalborg K.K.

Hereby declares that our products have not contained asbestos after 01/Feb./2003 of the production date.

Osaka, Japan

18 / June / 2012

(Place of issue)

(Date of issue)

Shunji Negoro / Quality Administrator

(Signature)



(Name, function)

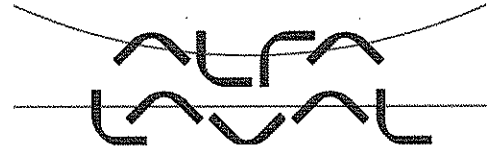

CERTIFICATE

We hereby certify that our High Speed separator (HSS) products and spare parts for these products are designed and produced in accordance with Alfa Laval demands.

These demands fulfill EU-regulations regarding Asbestos and Asbestos containing compounds.

This means that no Asbestos or Asbestos containing compounds are intentionally added to any HSS product or spare part delivered from Alfa Laval.

Tumba 2011-02-21

A handwritten signature in black ink, appearing to read "Tomas Zetterling".

Tomas Zetterling

Manager, Quality Assurance Group
Product Centre High Speed Separator
Alfa Laval Tumba AB

Supplier's Material Declaration

供給者材料宣言

- Asbestos -

アスベスト

Ref.: _____

文書番号

Company name: AMEROID JAPAN SERVICE CO.,LTD

会社名

Hereby declares that our products have not contained any asbestos of 6 minerals* after 29 / 06 / 12 of the delivery/production date.

ここに、2012年06月29日以降 出庫/製造 された当社の製品にはいかなる6鉱物*のアスベストを含んでいないことを宣言します。

6-12 1-CHOME,OKINA-CHO,
NAKA-KU,YOKOHAMA,JAPAN

2012/06/29

(Place of issue)

発行場所

(Date of issue)

発行日

KENICHI OHNO
TECHNICAL SUPPORT SECTION
SECTION CHIEF

大埜健一

(Name, function)

氏名

(Signature)

署名

* : 6 minerals are Actinolite, Amosite (Grunerite), Anthophyllite, Chrysotile, Crocidolite and Tremolite listed on appendix 8 2011 Guidelines for the development of the inventory of hazardous materials (Resolution MEPC.197 (62)).

* : 6 鉱物は、有害物質インベントリ作成ガイドライン(Resolution MEPC.197 (62))の付録 8 に示すアクリノライト、アモサイト、アンソフィライト、クリソタイル、クロシドライト及びトリモライトである。



BC TAECHANG INDUSTRIAL CORP.

640-1, Youngju-Dong, Chung-Ku, Pusan, Korea

Tel: +82-51-442-6191~2 Fax: +82-51-442-6193

E-mail: info@bcinternational.co.kr <http://www.bcinational.co.kr>

SUPPLIER'S MATERIAL DECLARATION

-ASBESTOS-

To : WHOM MAY IT CONCERNED

From : BC TAECHANG IND.CORP.

Date : July 9th 2012

This is to certify that any of our products (VULCAN PUMP, COMBO PUMP, AIRLESS SPRAY MACHINE & etc.....) nor their spare parts have no contains of ASBESTOS.

BC TAECHANG IND.CORP.

Kevin Kim, Sales Manager



BC COATING SYSTEMS
BC MARINE TAPE
BC PETRO TAPE
BC PIPE DRESSING-22

COMBO PUMP
RUSTBIT 500
AIRLESS SPRAY PUMP



ISO 9002



Supplier's Material Declaration
-Asbestos-

Ref : _____

Company name : BINGO VALVE CO.,LTD.

Hereby declares that our products have not contained asbestos after
October 1,2011 of the delivery date.

HIROSIMA,JAPAN
(Place of issue)

July 2,2012
(Date of issue)

Akira Takao
Technical Section
(Name, function)

A. Takao
(Signature)



BOLLFILTER
Protection Systems

Genuine Parts & Service

BOLL & KIRCH Filterbau GmbH, Postfach 14 20, D-50143 Kerpen

To whom it may concern

CERTIFICATE OF CONFORMITY

Herewith we confirm, that the BOLL & KIRCH FILTERBAU GMBH EQUIPMENT is manufactured in accordance to the International Rules against hazardous materials to 100 % without any Asbestos material.

Boll & Kirch Filterbau GmbH
Genuine Spare Division

Date: 29.6.12

BOLL & KIRCH FILTERBAU GMBH
Sindorf · Siemensstr. 10-14
D 50170 Kerpen
Postfach 1420 · D-50143 Kerpen

Postfach 14 20, D-50143 Kerpen
受信時刻: 2012年7月13日 16時18分

Tel.: +49 (0)2273-02-0
NO. 703137962323
www.bollfilter.de

	BLZ	Kto-Nr.	IBAN
Dresdner Bank	37080040	510366600	DE08 3708 0040 0310 0038 00
Deutsche Bank	37070000	6603600	DE22 2507 0000 0800 3500 00
Postbank	37010050	036533407	DE55 3701 0050 0365 0334 07
Commerzbank	37040444	005038400	DE72 2504 0044 0050 0284 00
Kreditcoöperative	37040200	107004100	DE69 3704 0000 0100 0411 00

Swift (BIC)-Code
DRSDE333
DEUTDE33
PBKDE33
COBADE33
COBKDE33

Geschäftsführer:
Dipl.-Kfm. Dr. Heinz Lux
Dipl.-Ing. Torsten Vogel
Reg.-Gericht Köln HRB 4178
USt-IdNr.: DE 121 052 477
Steuernr.: 203/229/0107

To whom it may concern

15.12.2011

Declaration of asbestos

We hereby declare that products and parts manufactured by Cargotec, MacGregor hatch covers,
are free from asbestos.

Yours sincerely,



Petteri Ostela
Contract Manager, Dry Cargo

Unit 4, Voltage, 6 Mollison Avenue
Enfield EN3 7XQ, United Kingdom

t +44 (0)1992 805400

f +44 (0)1992 805410

www.chartco.com

www.kelvinhughes.com

Asbestos Free Declaration

It is hereby declared that all products supplied by ChartCo Limited are 100 % free from Asbestos when delivered from the company.

This declaration also covers all packing materials etc.

Date: 13th May 2016

Place: Enfield, United Kingdom

Terry King

Global Operations Manager

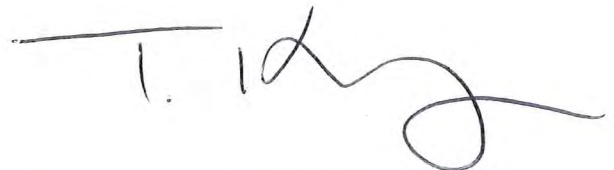

(Signature, company stamp)

CHARTCO LIMITED

S/NO: 11

Supplier's Material Declaration

製品供給者による宣誓書

- Asbestos -
- アスベスト -

Ref.: KH-0613a

Company name: CHUGOKU MARINE PAINTS, LTD.

Hereby declares that our products have not contained asbestos after October/1st/2004 of the delivery/production date.

2004年10月1日以降に引き渡し/製造した当社の製品はアスベストを含んでいないことを宣言いたします。

Otake, Japan/ 大竹、日本
(Place of issue)/(発行場所)

July 6, 2012/ 2012年7月6日
(Date of issue)/(発効日)

Environmental and Quality Assurance Dept.

環境・品質保証部

K.Kawahara

K. Kawahara

(Name, function)/(氏名及び職名)

(Signature)/(署名)

Supplier's Material Declaration

供給者材料宣言

- Asbestos -

アスベスト

Ref.: 20120709-1

文書番号

Company name: CHUOKOSAN Co., LTD.

会社名

Hereby declares that our products have not contained any asbestos of 6 minerals* after 01/07/12 of the delivery/production date.

ここに、2012年 7月 1日以降 出庫/製造された当社の製品にはいかなる6鉱物*のアスベストを含んでいないことを宣言します。

Note: delete either manufactured or delivered

注： 製造/出庫のどちらかを削除

4F, KANMO BILDG

1-11-8 NIHONBASHI MUROMACHI

CHUO-KU, TOKYO 103-0022 JAPAN

(Place of issue)

発行場所

July 9, 2012

(Date of issue)

発行日

Management Division

Division Director K. Kawabata

(Name, function)

氏名

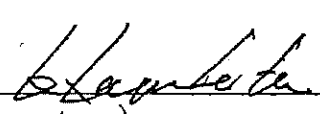
(Signature)

署名

* : 6 minerals are Actinolite, Amosite (Grunerite), Anthophyllite, Chrysotile, Crocidolite and Tremolite listed on appendix 8 2011 Guidelines for the development of the inventory of hazardous materials (Resolution MEPC.197 (62)).

* : 6 鉱物は、有害物質インベントリ作成ガイドライン(Resolution MEPC.197 (62))の付録 8 に示すアクリノライト、アモサイト、アンソフィライト、クリソタイル、クロシドライト及びトリモライトである。

Supplier's Material Declaration

供給者材料宣言

- Asbestos -

アスベスト

Ref: 20120709-1

文書番号

Company name: CHUOKOSAN Co., LTD.

会社名

Hereby declares that our products have not contained any asbestos of 6 minerals* after 01/07/12 of the delivery/production date.

ここに、2012年 7月 1日以降 出庫/製造された当社の製品にはいかなる6鉱物*のアスベストを含んでいないことを宣言します。

Note: delete either manufactured or delivered

注： 製造/出庫のどちらかを削除

4F, KANMO BILDG

1-11-8 NIHONBASHI MUROMACHI

CHUO-KU, TOKYO 103-0022 JAPAN

(Place of issue)

発行場所

July 9, 2012

(Date of issue)

発行日

Management Division

Division Director K. Kawabata

(Name, function)

氏名

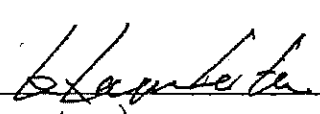

(Signature)

署名

* : 6 minerals are Actinolite, Amosite (Grunerite), Anthophyllite, Chrysotile, Crocidolite and Tremolite listed on appendix 8 2011 Guidelines for the development of the inventory of hazardous materials (Resolution MEPC.197 (62)).

* : 6 鉱物は、有害物質インベントリ作成ガイドライン(Resolution MEPC.197 (62))の付録 8 に示すアクリノライト、アモサイト、アンソフィライト、クリソタイル、クロシドライト及びトレモライトである。

Declaration of Asbestos-free

1. Document No.: 47541-AFD

2. Manufacturer Information :

Company Name	Compass Water Solutions
Company Address	1732 McGaw Ave, Irvine, CA 92614
Contact person	Jonathan Moore
Telephone Number	949-222-5777
FAX Number	949-222-5770
E-mail Address	info@compasswater.com

3. Product Information

Product Name	ULTRA-SEP
Type	Oil Water Separator
Serial/batch Number (If applicable)	47541 – 47542 – 47543 - 47544
Product Quantity (If applicable)	1
Other Information	

4. This company declares the product(s) described above are asbestos-free and in conformity with the relevant regulation(s) of the following document(s) as listed under 5.

5. Applicable Regulation(s) or other stipulated Requirement(s).

/Document No.	Title	Edition	Valid from
MSC.282(86)	Adoption of Amendments to the International Convention for the Safety of Life at Sea, 1974, as Amended – (adopted on 5 June 2009) - Annex – Amendments to the International Convention for the Safety of Life at Sea, 1974, as Amended		June 5, 2009

(Name/Job title): ENGINEERING MANAGER

(Signature/Corporate Seal): 

(Date of issue): 29-JUNE-2012

Supplier's Material Declaration

- Asbestos -

Ref.: 120626CHR001

Company name: CONHIRA Co.,Ltd

Hereby declares that our products have not contained asbestos after 12/July/2010 of the delivery date.

2-2-23,Kitakouge-cho,Imabari-city,

Ehime 794-0812,Japan

(Place of issue)

June 26,2012

(Date of issue)

Masayuki Yamamoto , Chairman

(Name, function)



(Signature)

S/NO: 20

Supplier's Material Declaration

- Asbestos -

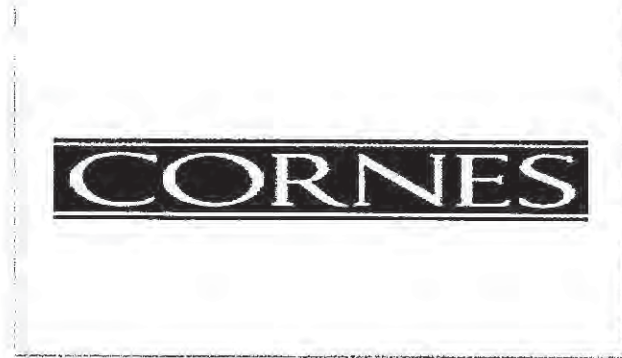

Company name: **Cornes Singapore Pte Ltd**

We hereby declare that our marine products have not contained asbestos after 23rd. December 2010 of our delivery date.

10 Anson Road ,#23-06/06A

International Plaza,Singapore 079903

(Place of issue)

18 July 2012

(Date of issue)

Tatsuya Okunaka

Managing Director

(Name, function)

A handwritten signature in black ink, consisting of a large, stylized loop and a smaller loop below it.

(Signature)

DAIHATSU

DAIHATSU DIESEL (ASIA PACIFIC) PTE. LTD.

2 SHENTON WAY, #16-02, SGX CENTRE 1, SINGAPORE 068804 TEL: 6589-9510 FAX: 6536-4964 CO. REG. NO: 198203401D

Ref. No : DSL-PMSG380FE

Date : 12 MAY 2016

M/s: Grindrod Ship Management
200 Cantonment Road, #03-01,
Southpoint,
Singapore 089763
Attn: Ms.Catherine Tay

Dear Sir,

Re: Supplier's Material (Asbestos Free) Declaration

We hereby declare that our products supplied by Daikai Engineering Pte Ltd (128, Pioneer Road, Singapore 639586) do not contain Asbestos Material. This has been effective since February 2006.

Yours Faithfully

For and on behalf of

DAIHATSU DIESEL (ASIA PACIFIC) PTE. LTD.



.....
T.NISHIYAMA
MANAGER
SPARE PARTS DEPT.

DAIHATSU

DAIHATSU DIESEL MFG. CO. , LTD.

1-30, Oyodo Nakai-chome, Kita-ku, Osaka, 531-0076 Japan

To whom it may concern

Supplier's Material Declaration
- Asbestos -

Ref.:SA12-153

Company name: DAIHATSU DIESEL MFG.CO.,LTD

Hereby declares that our products have not contained after Feb.2006
of the delivery/production date

Osaka,Japan

(Place of issue)

Mr.K.Yoshimura
General Manager
Global Customer Support Dept
(Name, Title and Department)

Jun.25,2012

(Date of issue)

(Signature)

2012年6月29日

株式会社ダイイチ殿

アスベスト不使用宣誓書

当社は、2003年12月より当社製品全般に対し、
アスベスト(下記6種類)は使用しておりません。

アスベスト:クリソタイル、クロシドライト、アモサイト、
アンソフィライト、トレモライト、アクチノライト

日本ピラー工業株式会社
営業本部
営業本部長 勝見僚一



Date : July.6. 2012

To : DAIICHI CO. ,LTD

SUPPLIERS MATERIAL DECLARATION -Asbestos-

We hereby declare that we do not use asbestos as of mentioned below 6types since delivery/production date (1.12.2003)

DESCRIPTION : CHRYSOLITE ASBESTOS, CROCIDOLITE ASBESTOS, AMOSITE ASBESTOS,
ANTHOPHYLITE ASBESTOS, TREMOLITE ASBESTOS, ACTINOLITE
ASBESTOS

Yours faithfully,

NIPPON PILLAR PACKING CO. ,LTD.

SALES HEADQUARTERS

GENERAL MANAGER RYOICHI KATSUMI

Ryoichi Katsumi

NIPPON PILLAR PACKING CO.,LTD.

お世話になります。

- 部品については 外資工業社-にて本部発行の書類(別紙①)
参考願います
- 製品については 機種別に発行しますので、都度ご用命下さい。
冊子701Lを参考にさせていただきます(別紙②)

宜しくお願いします

7/3 外資MR 福岡

別紙①

ダイキンMRエンジニアリング株式会社 御中

DAIKIN



平成 24年 6月 27日

ダイキン工業株式会社
サービス本部 企画部 部品G

アスベストに関する問合せの件

拝啓 貴社益々ご清栄のこととお慶び申し上げます。
平素は格別のご高配を賜り厚く御礼申し上げます。
さて、早速ではございますが標題の件、
ご報告させていただきますのでご理解賜りますよう御願い申し上げます。
何卒ご査収の程宜しくお願い致します。

敬具

【記】

【ご依頼内容】

- アスベスト不使用証明書について
アスベスト未使用の証明書は、サービス部品では、特に用意しておりません。
アスベストにつきましては有害化学物質の使用制限に関する法規制に
のっとり、サービス部品が現在出荷している補用部品には含まれておりません。
なお、過去に出荷した製品・補用部品への含有については、保証の限りでは
ありません。

以上

3/1頁②

Material Declaration

<Date of declaration>

Date: 12-July-2011

<Supplier Information>

Company Name	Daikin MR Engineering Co., Ltd.
Division Name	Equipment sales dept.
Address	Shin-osaka Central-tower, 5-5-15, Nishinukajima, Yodogawa-ku, Osaka-shi, Osaka, Japan
Contact Person	Atsuo Kohara
Telephone No.	81-6-4805-7293
Fax No.	81-6-4805-7321
E-mail Address	sales-marine@daikin.co.jp

<Product Information>

Product Name	Product Number	Product Total Mass		Product Information
		kg	set	
Air Conditioner	CAPA25GS-W	Indoor unit: CAPP25GS-W	9 kg	1 set
		Outdoor unit: CAPC25GS	35 kg	1 set

<Material Information>

Table	Material Name	Material Name	Threshold level	Intentionally added	Total Mass		Detailed Material Information
				Above threshold level?	kg	Unit	
Table A (Materials Listed in Appendix 1 of the Convention)	Asbestos	Asbestos	no threshold level	No			
	Polychlorinated Biphenyls (PCBs)	Polychlorinated Biphenyls (PCBs)	50mg/kg	No			
	Ozone Depleting Substance	CFCs	no threshold level	No			
		Halons		No			
		Other fully halogenated CFCs		No			
		Carbon Tetrachloride		No			
		1,1,1-Trichloroethane (Methyl chloroform)		No			
		Hydrochlorofluorocarbons		No			
		Hydrobromofluorocarbons		No			
		Methyl bromide		No			
	Organotin compounds	Tributyl Tin	2,500 mg/kg	No			
		Triphenyl Tin		No			
		Tributyl Tin Oxide (TBTO)		No			

Table	Material Name	Threshold level	Intentionally added	Total Mass		Detailed Material Information
			Above threshold level?	kg	Unit	
Table B (Materials Listed in Appendix 2 of the Convention)	Cadmium and Cadmium Compounds	100 mg/kg	No			
	Hexavalent Chromium and Hexavalent Chromium Compounds	1,000 mg/kg	No			
	Lead and Lead Compounds	1,000 mg/kg	Yes	10 or less	mg	Plating for wire of electronic parts on printed board
	Mercury and Mercury Compounds	1,000 mg/kg	No			
	Polybrominated Biphenyl (PBBs)	1,000 mg/kg	No			
	Polybrominated Diphenyl ethers (PBDEs)	1,000 mg/kg	No			
	Polychloronaphthalenes (Cl=3)	no threshold level	No			
	Radioactive Substances	no threshold level	No			
Certain Shortchain Chlorinated Paraffins	1%	No				



To Whom it may concern

ASBESTOS-FREE DECLARATION

According to SOLAS regulation II-1/3-5

We hereby declare that all materials delivered by Den-Jet Marine Pte Ltd do not contain asbestos or asbestos containing materials or components and are therefore completely free of asbestos in accordance with SOLAS regulation II-1/3-5

Date : 1st June 2013

Place : Singapore

LARS K. NIELSEN, MD.
Name, title

Signature, stamp



Supplier's Material Declaration

- Asbestos -

Hereby declares that asbestos is not contained the following product(s) including spare parts and supplies.

Company name: Diesel United, Ltd.

Product(s)/Type name;

Parts for after-sales service for diesel engines, DU-WCH type, delivered in and after April 2006.

5292,AIOI,AIOI-SHI,HYOGO KEN

Japan

(Place of issue)

June 29,2012

(Date of issue)

Mr.Minoru Tsubaki

General Manager

Customer Support Department

(Name, Title and Department)



(Signature)



DPM (Singapore) Pte Ltd

Company Registration No. 199004604Z
(Incorporated 1885 in Liverpool)

International Admiralty Chart Agent

Charts / Publications / Chart Correction Service / Auto New Edition
Replacement / Chart Folio Management Service / Electronic Charts



Certificate No: SNG 0403145

Supplier's Material Declaration - Non Asbestos -

**DPM (Singapore) Pte Ltd declares that our
products and packing materials do not
contains any asbestos.**



DPM (Singapore) Pte Ltd

Signature

Name:

Chong Chee Meng

Position:

Managing Director

Date:

31st July 2012



Singapore Office: 1 Maritime Square #09-72, (Use lift @ Lobby B) HarbourFront Centre, Singapore 099253
Tel: 065 6270 4060 Fax: 065 6276 3858 AOH: 065 9632 5268 Telex: RS 24505, 24605
E-mail: sales@dpmsingapore.com.sg Website: www.dpmsingapore.com.sg

Liverpool Office: DPM (UK) LTD (Formerly Dubois Phillips & McCallum Ltd)
Port of Liverpool Building, 2nd Floor, Pier Head Liverpool L3 1BY United Kingdom
Tel: 151 236 2776 Fax: 151 236 4577 Telex: 627 424 DUBOIS G E-mail: iaca@dpm.co.uk



S/NO: 13

Supplier's Material Declaration - Asbestos -

Ref.: Drew / 0098

Company name: DREW AMEROID (S) PTE LTD.

Hereby declares that our products have not contained asbestos after dd/mm/yy of the delivery/production date.

SINGAPORE
(Place of issue)

23/7/2012
(Date of issue)

Francis Tan / Sales Manager.
(Name, function)

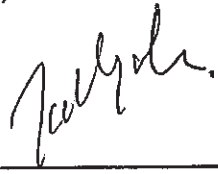
(Signature)



Supplier's Material Declaration

- Asbestos -

Ref.: KEMEL-20120620

Company name: EAGLE INDUSTRY CO.,LTD.-KEMEL COMPANY
(Formerly ; KOBELCO EAGLE MARINE ENGINEERING CO.,LTD.)

Hereby declares that our products have not contained asbestos after September / 2002 of the delivery date.

Product(s)/Type name;

Stern Tube Seal

Stern Tube Bearing

Intermediate Shaft Bearing

2-3-1 SHINHAMA ARAI-CHO

TAKASAGO-CITY, HYOGO 676-8670, JAPAN

(Place of issue)

20th June 2012

(Date of issue)

Masami Akatsu,

General Manager,

Quality Assurance Dept.

(Name, function)

M. Akatsu

(Signature)



To whom it may concern

Aug 7, 2012

SUB DECLARATION IN ACCORDANCE WITH SOLAS CHAP II-1/Reg. 3-5

This is to confirm that all Entel UK LTD products including packaging material are free from asbestos.

Please contact Entel UK for any further information or clarification.

Sincerely,

For and on behalf of Entel UK Ltd,



Jibrán Rizvi

Business Development Executive



Entel UK Limited
320 Centennial Avenue
Centennial Park
Elstree, Herts,
WD6 3TJ
United Kingdom
Tel : +44 (0) 20 8236 0032
Fax: +44 (0) 20 8236 0082
Email: enquiries@entel.co.uk
www.entel.co.uk



Incorporated in the United Kingdom
Registration No: 3143328

S/NO: 19



Co. Reg. No. 199905470E

E.W. LINER CHARTS & PUBLICATIONS PTE LTD

102F Pasir Panjang Road, #08-01 Citilink Warehouse Complex, Singapore 118530

Tel: +65 6323 0773 Fax: +65 6323 0775

Email: sales@ewliner.com Website: www.ewliner.com

SUPPLIER'S MATERIAL DECLARATION

ASBESTOS

To – OMC SHIPPING PTE LTD

We hereby declare that the items supplied by our company do not contain Asbestos.

SURANJAN NAIDU

General Manager

17th July 2012



An ISO9001:2008 Registered Company



Supplier's Material Declaration

- Asbestos -

Hereby declares that asbestos is not contained the following product(s) including spare parts and supplies.

Company name: EXENO YAMAMIZU CORPORATION

Product(s)/Type name;

HOPE SYSTEM

WATER TURBIN FAN

AIR WINCH

TOKYO, JAPAN

(Place of issue)

21 JUNE, 2012

(Date of issue)

TAIZO MORITA

GROUP LEADER

BUSINESS DEPT.NO.1

MARINE SALES GROUP

(Name, Title and Department)

(Signature)

Supplier's Material Declaration

- Asbestos -

Ref.: FB-002012-0701

Company Name : FB INDUSTRIAL CO., LTD.

Hereby declares that our products have not contained asbestos after 2006.4.1 of the production date.

Osaka/Japan

(Place of issue)

2012/7/1

(Date of issue)

HaruhiroKimura, President

(Name, function)



(Signature)

FB INDUSTRIAL CO., LTD.
1-12-17 TAKAIDA-NAKA, HIGASHI-OSAKA CITY
OSAKA 577-0065, JAPAN
TEL:(06)6787-1581 FAX:(06)6783-0071

Supplier's Material Declaration

-Asbestos-

Hereby declares that all of our supplying products have not contained asbestos after 1st
/July/2012 of delivery date.

Kobe
(Place of issue)

12/05/2016
(Date of issue)

for Yoshi Saito, Senior Manager
(Name, Position)

(Signature)



SINO: 04



FUJI TRADING (SINGAPORE) PTE. LTD.

24 CHIA PING ROAD, SINGAPORE 619976. TEL: (65) 6264 1755 FAX: (65) 6265 0443
GST Reg. No: M2-0052016-5 • Co Reg. No: 198201088K

Date : July 6' 2012

To our valued customers

Dear Sirs,

Re: Supplier's Material Declaration - Asbestos

As per Solas regulation Chapter II – 1 Reg 3-5, Fuji Trading (Singapore) Pte Ltd, hereby declares that after 1st July 2012, asbestos shall not be contained in any ship's stores/articles supplied by Fuji Trading Singapore.

Yours Faithfully,

O. Sasaki,
Executive Director
Fuji Trading (Singapore) Pte Ltd

SUPPLIER'S MATERIAL DECLARATION

NON ASBESTOS

WE, HANAPOWER SYSTEM SERVICE CO., LTD., DECLARE THAT OUR PRODUCTS AND PACKING MATERIALS DO NOT CONTAIN ANY ASBESTOS.

SIGNATURE : Jong Jin, Kim

NAME : JONG JIN KIM (MR.)

POSITION : MANAGING DERECTOR

DATE : 13RD MAY 2016

アスベスト不使用宣言書 Asbestos-free declaration

Doc. No. QM1213

Date: 2012/07/03

関係各位 殿

To Whom It May Concern

〒673-0037

兵庫県明石市貴崎5丁目8番70号

TEL 078-923-3451 FAX 078-923-0555

8-70 5chome Kisaki Akashi Hyougo Japan

阪神内燃機工業株式会社

THE HANSHIN DIESEL WORKS, LTD.

品質保証部

QUALITY ASSURANCE DEPT.

宣言 Declaration

SOLAS条約改正に伴い、2011年以降船舶に搭載される材料に関して例外なくアスベスト含有材料の使用が全面的に禁止されました。これを受け、IACS(国際船級連合)の確認方法として、各機器メーカーより提出される「アスベスト不使用宣言書」により確認することとしており、2012年7月1日以降に起工される船舶、及び就航船においては2012年7月1日以降に交換される部品(予備品含む)には「アスベスト不使用宣言書」が必要となります。

上記に基づき、当社が製造する、全ての製品(主機関、船尾軸系装置、電気設備、及び補用品他)には下記に示す6物質のアスベスト含有製品を使用していないことをここに宣言します。

英文

As The SOLAS strengthened its regulation, it bans new installation of materials including asbestos to the ships without any exceptions since January 1st, 2011.

As a confirmation of IACS, ASBESTOS-FREE DECLARATION shall be submitted by each machinery maker.

ASBESTOS-FREE DACARATION is required for the vessel which is keel-laid and spare parts for ships in service on and after July 1st, 2012.

Hence, we, The Hanshin Diesel Works, Ltd. hereby declare that we do not use any materials including asbestos for our products (Main Engine, Stern Equipment, Electrics and other spare parts etc.)

使用していないアスベスト6物質

6 asbestos materials which we do not use

アクチノライト アスベスト actinolite asbestos	クリソタイル chrysotile
アモサイト amosite	クロシドライト crocidolite
アンソフィライト アスベスト anthophyllite asbestos	トレモライト アスベスト tremolite asbestos

以上

Yours faithfully,

DECLARATION AND CONFIRMATION OF ASBESTOS FREE-PRODUCTS

This document serves as a Declaration and Confirmation from the Manufacturer, HATLAPA Uetersener Maschinenfabrik GmbH & Co. KG, Uetersen, that asbestos materials are not utilized in any assembly or sub-assembly component during the construction of any of our instrumentation product lines. Also declare that all items supplied are 100 % asbestos free.



HATLAPA
Uetersener Maschinenfabrik GmbH & Co. KG
Tornescher Weg 5-7
25436 Uetersen / Germany

Phone: +49-4122 / 711-0
Internet: <http://www.hatlapa.de>

Declaration of Conformity - Asbestos Free -

We hereby declare that our products have not contained
asbestos after 4th Aug., 2005 of the production date.

Company Name: HEISHIN PUMP WORKS CO.,LTD.

Place of issue : 1-5-30 Furuta,Harima-cho,Kako-gun,Hyogo,Japan

Date of issue : 21st June, 2012

Name, function : M. Nakatani, Manager of Quality Control Dept.

Signature : 





HEMPEL A/S
Lundtoftegaardsvej 91
DK-2800 Kgs. Lyngby
Denmark
www.hempel.com

Tel: +45 45 93 38 00
Fax: +45 45 88 55 18
E-mail: hempel@hempel.com
CVR. nr.: 5994 6013

To whom it may concern

DATE 12 May 2015

YOUR REF:

OUR REF:

Statement concerning Asbestos Free

As per today, we hereby confirm:

To the best of our knowledge, Hempel does not intentionally introduce asbestos* in our products.

* "asbestos" comprises any of the following eight mineral names and associated "Chemical Abstracts Service" (CAS):

Chemical name	CAS-no.
Chrysotile	12001-29-5
Chrysotile	132207-32-0
Amosite	12172-73-5
Crocidolite	12001-28-4
Anthophyllite	77536-67-5
Tremolite	77536-68-6
Actinolite	77536-66-4

Various environmental protection and product safety regulations, directives, standards and initiatives, define "intentionally introduced" to mean "deliberately utilised during the manufacture of the formulation of a material where its continued presence is desired in the final product to provide a specific property, appearance or quality".

Furthermore, Hempel is in the process of getting confirmation from our suppliers that their raw materials do not contain asbestos. We have that confirmation from around 91% of our suppliers at this point in time, and expect that the remaining 9% will give us their confirmation within the next six months.

This letter shall be construed and interpreted according to the laws of Denmark.

Yours Sincerely,
HEMPEL A/S

Charlotte Rahbek
Group HSE-Products Manager

Disclaimer

This information is given to you in good faith to the best of our current reasonable knowledge, taking into consideration current status of technology as generally applied in the industry and assuming that you will use our Products for its intended purposes only. With reference to the safety data sheets, you have full responsibility to use HEMPEL Products consistent with such information, including but not limited to any restrictions on use of the Products. Once any HEMPEL Product is within your custody or control, you shall have full responsibility for any liability arising out of the storage, handling, transportation, sale, use, reuse, recycling and/or disposal of any such HEMPEL Product, and of any derivative product, co-product, by-product or waste product therefrom, including the use of any such product alone or in combination with other substances, and compliance with any laws or regulations relating thereto, including but not limited to those affecting testing for uses of such products

HEMPEL

Supplier's Material Declaration

- Asbestos -

Ref.: NTS-QA1206-006

Company name: HISAKA WORKS, LTD.

Hereby declares that our products have not contained asbestos after 1st Apr. 2004 of the delivery date.

2-1-48, HIGASHI-KONOIKECHO

HIGASHI-OSAKA CITY OSAKA, JAPAN Jun. 29, 2012

(Place of issue)

(Date of issue)

S. HATANAKA / QA MANAGER

(Name, function)

S. Hatanaka

(Signature)

Hitachi Zosen

Hitachi Zosen Corporation

7-89, Nanko kita 1-chome, Suminoe-ku, Osaka 559-8559, Japan

Phone: +81-6-6569-0502 Facsimile: +81-6-6569-0503 Email: de-hzds@hitachizosen.co.jp

June 29, 2012

Supplier's Material Declaration

- Asbestos -

Company name: Hitachi Zosen Corporation

Hereby declares that our products have not contained asbestos on or after September 1, 2006 of the deliver / production date.

Product(s) name; Main diesel engine including after sales parts.

Kumamoto, Japan

(Place of issue)

June 29, 2012

(Date of Issue)

Yoshihisa Furukawa
General Manager, QA Department.

(Name, Function)

Y. Furukawa

(Signature)

Declaration of "Non-asbestos" material

We, "hp-TECHNIK GmbH", hereby declare that all materials used in our products and packing materials, are free of asbestos.

We do not utilize asbestos or asbestos-containing materials in any of our products nor the products or parts as manufactured by our suppliers.

No asbestos or any similar materials causing an environmental impact are being applied or handled in connection with the present activities.

signature



Dirk Retschlag (Dipl.-Ing. FH)
Head of Technical Department
- hp-TECHNIK GmbH -

Karlsruhe, 11.05.2016

hp-TECHNIK GmbH
Industriepumpen, Förderaggregate
+ Anlagenbau
Gablonzer Straße 21
76185 Karlsruhe
Tel. 0721 956180, Fax 9561828

Stempel
Stamp

Gablonzer Straße 21
D-76185 Karlsruhe
Postfach 21 10 10
D-76160 Karlsruhe
Tel. 07 21 / 956 18-0
Fax 07 21 / 956 18-27 Einkauf
Fax 07 21 / 956 18-28 Vertrieb
✉ info@hptechnik.com

Geschäftsführer:
Ulf-Henning Elsässer
Inge Aalfeld

Ust.-Id.-Nr. DE 14360 1793
Steuer Nr. 35008/01626
Amtsgericht Mannheim
HRB-Nr. 104302

Sparkasse Karlsruhe
Kto.: 22 323 786, BLZ: 660 501 01
IBAN DE68 6605 0101 0022 3237 86, SWIFT-BIC KARSDE 66
BW-Bank Karlsruhe
Kto.: 4 025 036, BLZ: 600 501 01
IBAN DE72 6005 0101 0004 0250 36, SWIFT-BIC SOLADE ST
Kreissparkasse Esslingen
Kto.: 999 939, BLZ: 611 500 20
IBAN DE04 6115 0020 0000 9999 39, SWIFT-BIC ESSLDE 66

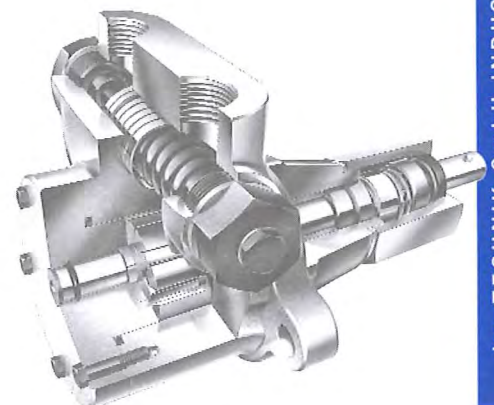

ASBESTOS FREE CERTIFICATE

for

All HiMSEN Engines

Maker : Hyundai Heavy Industries Co.,Ltd, Engine and Machinery Division
Equipments : Diesel Generator Engines

We hereby confirm that asbestos-free materials have been used only on the above mentioned products which are installed on the vessel in question.

For and on behalf of
HHI-Engine and Machinery Division
Four-stroke Engine Design Dep't
B. Y. Kim / General Manager

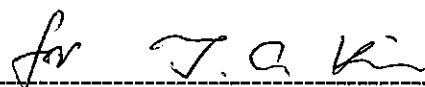

Date: December 15, 2010

Supplier's Material Declaration

- Asbestos -

Ref.: CHT-1127

Hereby declares that asbestos is not contained the following product(s) manufactured after 1999 including spare parts and supplies.

Company name: IHI Corporation

Product(s)/Type name:

 Deck Crane

11-1, Kitahama-machi, Chita-city, Aichi

478-8650 Japan

(Place of issue)

3rd July, 2012

(Date of issue)

Eizo Ushikoshi

Manager

Safety & Quality Assurance G.

Bushiness Management Dept.

Infrastructure Operations

(Name, function)



(Signature)

Supplier's Material Declaration

- Asbestos -

Ref.: CHT-1126

Hereby declares that asbestos is not contained the following product(s) manufactured after 1999 including spare parts and supplies.

Company name: IHI Corporation

Product(s)/Type name:

 Deck Machinery (Windlass, Mooring winch etc.)

11-1, Kitahama-machi, Chita-city, Aichi

478-8650 Japan

(Place of issue)

3rd July, 2012

(Date of issue)

Eizo Ushikoshi

Manager

Safety & Quality Assurance G.

Bushiness Management Dept.

Infrastructure Operations

(Name, function)



(Signature)

Supplier's Material Declaration

- Asbestos -

Hereby declares that asbestos is not contained the following product(s) including spare parts and supplies.

Company name: IHI Corporation

Product(s)/Type name;

Turbocharger Complete and spare parts

Kanagawa, Japan June 25, 2012

(Place of issue) (Date of issue)

Mr. Fumihiko Kobayashi

Manager

Quality Assurance Department F. Kobayashi

(Name, Title and Department) (Signature)

Supplier's Material Declaration

- Asbestos -

Hereby declares that asbestos is not contained the following product(s) including spare parts and supplies.

Company name: IKNOW MACHINERY CO.,LTD.

Product(s)/Type name:

DECK CRANE, GANTRY CRANE, CHIP UNLOADER

NAGASAKI, JAPAN

(Place of issue)

JUNE 22, 2012

(Date of issue)

Mr.T.Hattori.

Director

(Name, Title and Department)



(Signature)

Supplier's Material Declaration

- Asbestos -

Hereby declares that asbestos is not contained the following product(s) including spare parts and supplies.

Company name: IKNOW MACHINERY CO.,LTD.

Product(s)/Type name:

HATCH COVER

NAGASAKI, JAPAN

(Place of issue)

JUNE 22, 2012

(Date of issue)

Mr.I.Osugi.

Director

(Name, Title and Department)

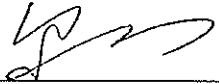

(Signature)



Marine Pumps & Other Ship Machineries

18-1, Awaji 3-Chome
Higashiyodogawa-ku,
Osaka 533-0001, Japan



ESTABLISHED 1919

ISHII KOSAKUSHO CO., LTD.

(ISHII MACHINERY WORKS)

Telephone: 06-6322-6731 (Rep)

Telefax: 06-6322-6748

Supplier's Material Declaration - Asbestos -

Company name: Ishii Kosakusho Co. Ltd.

Hereby declares that our products have not contained asbestos
after Jul 1, 2002 of the production date.

18-1, Awaji 3-Chome
Higashiyodogawa-ku,
Osaka 533-0001, Japan
(Place of Issue)

Jul 9, 2012
(Date of Issue)

M. Yoshikawa
General Manager
(Name, function)

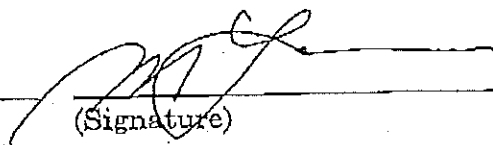
(Signature)

Supplier's Material Declaration

- Asbestos -

Ref: _____

Company name: J. P. Sauer & Sohn Maschinenbau GmbH _____

Hereby declares that our products have not contained asbestos after 31/07/2006 of the delivery/production date.

Kiel
(Place of issue)

02.07.2012
(Date of issue)

Mirau
J. P. SAUER & SOHN
MASCHINENBAU GMBH
Brauner Berg 15 - 24159 Kiel

S. Mirau, Quality assurance
(Name, function)

(Signature)



JINSAN MARINE MANAGEMENT CO., LTD.

1396 MAEAM-DONG NAM-GU, ULSAN, KOREA



TEL. 82 52 228 7800
FAX. 82 52 228 7890-1
TLX K52303 JINSAN
E-mail : jinsan@jinsankorea.co.kr

PART SALES AGENT FOR
HYUNDAI
HEAVY INDUSTRIES CO.,LTD
ENGINE & MACHINERY DIVISION

- HHI ENGINE A/S PARTS SUPPLY
- MARINE EQUIPMENT & STORES
- PROVISIONS & BOND STORES
- CHEMICAL DETERGENT

Supplier's Material Declaration - Asbestos Free -

Company name: JINSAN MARINE MANAGEMENT CO.,LTD.

Hereby declares that our products have not contained asbestos after 1st/JULY/2015 of the delivery/production date.

Place of issue : Ulsan Korea

Date of issue : 05TH MAY 2016

SINCERELY YOUR
JINSAN MARINE MANAGEMENT CO.,LTD.

CAPTAIN W. S. LEE / PRESIDENT

Supplier's Material Declaration

- Asbestos -

Ref.: QJW12167

Company name: Japan Radio Co. Ltd.

Hereby declares that our Marine Electronics products and parts have not contained asbestos on and after 1st / July / 2002 of the ~~delivery~~/production date.

Quality Assurance Department

Marine Electronics

(Place of issue)

22nd June, 2012

(Date of issue)

Koichi SAITO / General Manager

(Name, function)

Koichi Saito

(Signature)

Ref.No.: JQR-120615TI

Asbestos Free Products: Declaration

Manufacturer's Name: JRCS MFG. CO.,LTD.

Hereby declares that all products manufactured after the production date of April 1995 do not contain asbestos.



(Signature)

Signed:

Tomohiro Inada
Team Leader, Quality Assurance Group, Toyoura Plant

Address of Manufacturer:
2155 Kawatana, Toyoura-cho, Shimonoseki
Yamaguchi, 759-6301 Japan

Date of issue: June 26, 2012

JRCS[®]

Supplier's Material Declaration

- Asbestos -

Ref.: 12GK147

Company name: KANAGAWA KIKI KOGYO CO., LTD.

Hereby declares that our products have not contained asbestos after
1/Sep./2006 of the production date.

No.19-1, OKAMURA 8, ISOGO-KU,
YOKOHAMA, JAPAN.

(Place of issue)

27/Jun./2012

(Date of issue)

K.Nonaka, Manager

(Name, function)

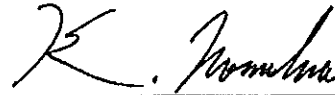

(Signature)

Supplier's Material Declaration

- Asbestos -

Ref. : SMDA KSW 20120712

Company name : Kashiwa Co., Ltd.

Hereby declares that our products have not contained asbestos after 01/04/'90 of the delivery/production date.

Ibaraki, Japan
(Place of issue)

2012/07/12
(Date of issue)

A. Yoshida – General Manager Q.C.Dept.
(Name, function)

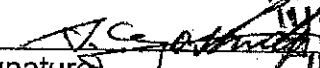
(Signature)



Supplier's Material Declaration

- Asbestos -

Ref: K120702-2

Company name: KISHIGAMI VALVE CO., LTD.

Hereby declares that our products have not contained asbestos after 02072012 of the delivery/production date.

2-54minamikinomoto yao city Osaka Japan 2 July. 2012

(Place of issue)

(Date of issue)

President-director

(Name, function)

K. Kishigami

(Signature)



HEAD OFFICE AND WORKS
1, MINAMI-FUTAMI, FUTAMI-CHO,
AKASHI, HYOGO PREF., 674-0093, JAPAN

MAKER
OF
MARINE DIESEL ENGINES

TEL : + 81-78-949-0801
FAX : + 81-78-949-0811

Date: July 6, 2012

Ref.: KB-353

To whom it may concern

Supplier's Material Declaration "Asbestos"

Company name : Kobe Diesel Co., Ltd.

It is hereby declared that our parts and supplies in relation to KOBE DIESEL-
MITSUBISHI UE DIESEL ENGINE have not contained asbestos after January 1,
2006 of the delivery date.

T. Hosokawa, Manager
Parts Supply Section
Business Department
Business Promotion Division

Supplier's Material Declaration

- Asbestos -

Ref: _____

Company name: KUNIMORI ENGINEERING WORKS CO.,LTD

Hereby declares that our arranged spare parts have not contained asbestos after 01/Sept./2006 of the delivery date.

Kobe City, Japan
(Place of issue)

July 1, 2012
(Date of issue)

Yoshihiro Toyosawa/ Director
(Name, function)

(Signature)

Supplier's Declaration of containing no Asbestos

I declare that no Asbestos is contained in the objects described below.

1) Issuer's name : Kyoritsu Kikai Co., Ltd.

Issuer's address : 4-1-45, Minami, Mihara-shi, Japan

2) Objects of the declaration: All products supplied by our company
Including below products & Spare Parts:
Hose Handling Cranes
Provision Cranes
Accommodation Ladders
Windows
Spare Parts
Others

3) The objects of the declaration described above are in conformity with the following.

Document No.	Title	Edition	Date of issue
<u>KS-QMS-2010</u>	<u>QUALITY MANAGEMENT SYSTEM</u>	<u>13th issue</u>	<u>2011.06.27</u>
02-306	ISO 9001 2008		<u>2011.12.26</u>

4) Signed for and behalf of

Yoshiharu Ikeuchi , President

Tokio Tsunoda , Director of Production Sec.



(Signature)

Mihara, Japan

(Place of issue)

2012/07/04

(Date of issue)

To whom it may concern

Dear Sirs,

ASBESTOS-FREE DECLARATION

Following IMO Res. MSC.282 (6), adopting SOLAS II-1/A 3-5 (SOLAS 2009 Amendment) and totally prohibits the use of Asbestos in installations on board all ships from 01 January 2011 and onwards, HATLAPA declares that all products/equipment/materials as per below product list have been designed, manufactured and packed to be free of asbestos.

Product list:

- deck machinery, steering gear and compressors

For definition of asbestos we refer to 6 minerals:

1. Actinolite CAS 77536-66-4
2. Amosite (Grunerite) CAS 12172-73-5
3. Anthophyllite CAS 77536-67-5
4. Chrysolite CAS 12001-29-5
5. Crocidolite CAS 12001-28-4
6. Asbestos Tremolite CAS 77536-68-6

CAS-numbers are consistent with OSHA's the EU's and the USCG/EPA's definition of asbestos.

Yours sincerely



Thorsten Schäfer
Head of Fleet Support

MacGregor Hatlapa GmbH & Co. KG

MacGregor offers HATLAPA, PORSGRUNN and PUSNES products

**MacGregor Hatlapa
GmbH & Co.KG**
Tornescher Weg 5-7
25436 Uetersen, Germany
Tel +49 (0) 4122 711-0
www.hatlapa.de
www.macgregor.com
Part of Cargotec Corporation

Managing Director:
Dr.-Ing. Alexander Nürnberg
Business registration
Amtsgericht Pinneberg:
HRA 0499 EL
Verwaltungsgesellschaft:
HRB 1560 EL
UST.ID-Nr. DE 134527127

Supplier's Material Declaration

- Asbestos -

Ref.: S4-120628-EK1

This is to certify that all the equipment and spare parts supplied by Makita on and after July 1st, 2002 do not use materials including asbestos, with a few exceptions.

Please pay close attention to a possibility that the parts of the following 2 engine types you purchased from us use the materials including asbestos.

In case of replacing the following parts hereafter, please be sure to use the products of the new non-asbestos type.

弊社において 2002 年 7 月 1 日以降に供給された、全ての付属機器及び予備品等の品物は一部の例外を除きアスベストを含む材料を使用していないことを宣言致します。

当社から購入された就航船用サービス部品の内、下記機種の一部についてはアスベスト含有製品を採用している可能性があるため使用しないよう十分注意願います。

今後下記部品を新替える場合は必ず新型ノンアスベストタイプの製品を採用願います。

1. MAN-B&W L/S35MC

521A -3 : PACKING for T/C gas outlet (purchased from us before July 2009)

過給機排ガス出口用パッキン : 2009 年 7 月以前に当社から購入された製品

2. MAN-B&W S26MC

531B : GASKET for starting air inlet pipe (purchased from us before December 2006)

始動空気入口枝管用ガスケット : 2006 年 12 月以前に当社から購入された製品

Company name: MAKITA CORPORATION

Product(s)/Type name;

MAKITA-MITSUI MAN B&W S26MC · L/S35MC · S42MC · S46MC-C

MAKITA Original All 4Cycle Engines

Asahimachi 4-1-1 Takamatsu Kagawa Japan

(Place of issue)

28/06/2012

(Date of issue)

Shiro Yoshioka

Department Manager

Parts Sales Department

After-Sales Service Division

(Signature)

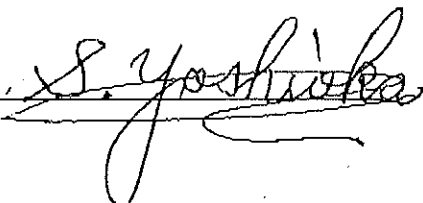

Supplier's Material Declaration

— Asbestos —

Hereby declares that asbestos is not contained the following product(s)
including spare parts and supplies.

Company name : MATSUBARA IRON WORKS LTD.

Product (s) /Type name ;

All the Products

Osaka Japan
(Place of issue)

2012/6/22
(Date of issue)

MIKIO TAKEMURA, President
(Name, Title and Department)

Mikio Takemura
(Signature)

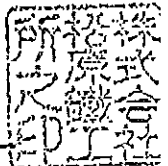

Supplier's Material Declaration
— Asbestos —

Ref.: Refrigeration machineries

Company name: MAYEKAWA MFG. CO.,LTD

Hereby declares that our products have not contained asbestos after 1/9/2005
of the delivery/production date.

MORIYA PLANT
2000 Tatsuzawa, Moriya City, Ibaraki Pref.
(Place of issue)

5/7/2012
(Date of issue)

TAKIO KATO
Quality control group Manager
(Name,function)

J. Kato
(Signature)



MITSUBISHI HEAVY INDUSTRIES, LTD.
NAGASAKI SHIPYARD & MACHINERY WORKS
1-1, AKUNOURA-MACHI, NAGASAKI, 850-8610, JAPAN

TEL:+81-95-828-6622
FAX:+81-95-828-6633

Supplier's Material Declaration

- Asbestos -

Date: 9th July 2012
Ref. No: NH0-2012070901

Hereby declares that asbestos is not contained the following product(s) / delivered on and after 1st Oct. 2006, including spare parts and supplies.

Company name: MITSUBISHI HEAVY INDUSTRIES, LTD.

Product(s)/Type name;

- Marine Boilers and Exh. Gas Economizers (All type)
- Marine Turbines (All type)
- Turbochargers (All type)
- Propellers (All type)
- Steering gears (All type)
- Fin stabilizers (All type)
- and
- Spare parts / supplies for all products

Project MEET & strategic planning Gr.
Marine Machinery Department
Nagasaki, Japan
(Place of Issue)

9th July 2012
(Date of issue)

D. Takeuchi, Manager
(Name, function)

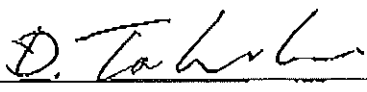
(Signature)

MITSUBISHI HEAVY INDUSTRIES CO., LTD.
POWER SYSTEMS
**2-1-1 SHINHAMA ARAI-CHO
TAKASAGO HYOGO JAPAN**

TEL : +81-79-445-6104

FAX : +81-79-445-6933

Ref. No. : GET-1117

3, Aug, 2012

Supplier's Material Declaration - Asbestos -

Hereby declares that asbestos is not contained in the following products manufactured / delivered on and after 3rd, Aug, 2012, including spare parts and supplies.

For reference MHI Takasago stopped using Asbestos products since Apr. 2005.

After this, there is no delivery experience of the asbestos product.

Company name : MITSUBISHI HEAVY INDUSTRIES, LTD.
POWER SYSTEMS HEADQUARTERS (TAKASAGO)
HYDRAURIC & ENERGY DEPARTMENT
WATER JET & PUMP DRIVING TURBINE GROUP

Product(s)/Type name :

CARGO OIL PUMP (ALL TYPE)
WATER BALLAST PUMP (ALL TYPE)
CARGO OIL PUMP TURBINE (ALL TYPE)
WATER BALLAST PUMP TURBINE (ALL TYPE)
 and
Spare parts / supplies for all products

Takasago, Japan
 (Place of Issue)

3rd, Aug, 2012
 (Date of Issue)

K. Konno, Manager
 (Name, position)

K. Konno
 (Signature)



MITSUBISHI HEAVY INDUSTRIES, LTD.
SHIMONOSEKI SHIPYARD & MACHINERY WORKS

16-1,2-CHOME,HIGASHIYAMATO-MACHI
SHIMONOSEKI,JAPAN

TEL:+81-83-267-8419
FAX:+81-83-267-8556

Ref. No. DR00502730
13th July, 2012

Supplier's Material Declaration
- Asbestos -

Hereby declares that asbestos is not contained in spare parts and supplies for the following products supplied on and after 1st January, 2003.

Company name: MITSUBISHI HEAVY INDUSTRIES, LTD.
Shimonoseki Shipyard and Machinery Works

Product(s)/Type name:

Spare parts and supplies supplied on and after 1st January, 2003

for the following products

DECK CRANE (ALL TYPE)

HOSE HANDLING CRANE (ALL TYPE)

WINDLASS (ALL TYPE)

MOORING WINCH(ALL TYPE)

PUMP UNIT for DECK MACHINERY (ALL TYPE)

Shimonoseki, Japan
(Place of Issue)

13th July, 2012
(Date of Issue)

T.Kuroda
Manager, Machinery designing group
(Name, function)

T. Kuroda
(Signature)

Supplier's Material Declaration

- Asbestos -

Ref.: _____

Company name: MISTUBOSHI CO.,LTD



Hereby declares that our products have not contained asbestos after dd/mm/yy of the delivery/production date.

2-2-5 TIMORI-CHO, SUMA-KU,
KOBE-SHI, HYOGO-KEN, JAPAN

5 July 2012

(Place of issue)

(Date of issue)

Nozomu Hara

N. Hara

(Name, function)

(Signature)

三菱重工 サービス通報

三菱重工業株式会社 原動機事業本部 船用機械・エンジン事業部

船用ディーゼル部 サービス技術課

〒652-8585 神戸市兵庫区和田崎町一丁目1番1号

TEL (078)672-3819(ダイヤルイン) FAX (078)672-5985

(1/2)

件名	アスベストを含む材料を使用していない旨の宣言書 についてのお知らせ	種別	三菱 UEC ディーゼル機関
		型式	UEC 全機種
		資料番号	MSI-1259

IACS(国際船級協会)での統一解釈 SC249 の内容に基づき、国際航路を運航する船舶には、新造船および就航船向の供給部品共にアスベストを含む材料を使用していない旨の宣言書が必要となります。三菱重工業では、同解釈に基づき、2006年1月1日以降に出荷された船用2ストローク大形ディーゼル機関では、その付属品(予備品、要具等)およびアフターサービス部品を含めて、アスベストを含む材料を使用しておりません。そのための「アスベストを含む材料を使用していない旨の宣言書」が、次ページの通り、弊社品証部門より発行されておりますので、お知らせ致します。

来歴	新規作成: H24年6月29日	承認	点検	作成	船用ディーゼル部
		山本	若月	若月	サービス技術課
					平成24年6月29日作成



MITSUBISHI HEAVY INDUSTRIES, LTD.

CENTRAL POST OFFICE
BOX NO. 1086, KOBE
CABLE ADDRESS:
DOCK KOBE

1-1, 1-CHOME, WADASAKI-CHO, HYOGO-KU
KOBE, JAPAN

TELEPHONE:
+81-78-572-5993
FACSIMILE NO.:
+81-78-572-3180

Date: 27th June 2012

Ref. No.: UJG-20120475

Supplier's Material Declaration

=== Asbestos ===

アスベストを含む材料を使用していない旨の宣言書

In conformity with IACS UI SC249, we hereby declare that asbestos is not contained in our any product including spare parts and supplies of "two (2) stroke marine diesel engines and their fittings" which delivered on and after 1 January 2006.

IACS UI SC249 に準拠し、2006年1月1日以降に出荷した2ストローク船用ディーゼルエンジン及びその付属品についての予備品や消耗部品を含むいかなる製品にもアスベストを含んでいないことを宣言します。

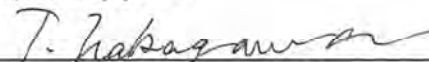

Respectfully yours,

Tatsuo Nakagawa, Manager,
Machinery & Electronic Equipment QA section
QA Department
Nuclear Energy Systems

Supplier's Material Declaration

- Asbestos -

Ref: SG-SMD0001

Hereby declares that asbestos is not contained the following product(s)

* manufactured on or after 01/07/2012 or

* delivered on 01/07/2012

including spare parts and supplies.

*: as delete appropriately

Company name: MITSUBISHI HEAVY INDUSTRIES, LTD.

Product(s)/Type name:

ELECTRO-HYDRAULIC STEERING GEAR

(include spare parts)

NAGASAKI SHIPYARD &

MACHINERY WORKS

(Place of issue)

22 JUNE, 2012

(Date of issue)

YOSHIYUKI ONO

MARINE MACHINERY EQUIPMENT

DESIGNING SECTION

(Name, function)

(Signature)

Supplier's Material Declaration

- Asbestos -

Ref: Oil Purifier

Hereby declares that asbestos is not contained the following product(s)
delivered since June/1988 including spare parts and supplies.

Company name: Mitsubishi Kakoki Kaisha, Ltd.

Product(s)/Type name:

Oil Purifier

SJ10T, SJ11T, SJ15T, SJ16T, SJ20T, SJ25T, SJ30T, SJ40T, SJ60T

SJ10P, SJ15P, SJ20P, SJ25P, SJ30P, SJ40P, SJ60P

SJ10EH, SJ15EH, SJ20EH, SJ25EH, SJ30EH, SJ40EH, SJ60EH

SJ10F, SJ15F, SJ30F, SJ40F, SJ50F, SJ80F, SJ100F

SJ10FP, SJ15FP, SJ30FP, SJ40FP, SJ50FP, SJ80FP, SJ100FP

SJ10FH, SJ15FH, SJ30FH, SJ40FH, SJ50FH, SJ80FH, SJ100FH, SJ130FH

SJ10G, SJ20G, SJ30G, SJ50G, SJ60G, SJ70G, SJ100G, SJ120G, SJ150G

SJ10GH, SJ20GH, SJ30GH, SJ50GH, SJ60GH, SJ70GH, SJ100GH,

SJ120GH, SJ150GH

SJ700, SJ08

OP1000, OP3000

Mitsubishi Kakoki Kaisha, Ltd. Kawasaki works

22, June 2012

Safety, Quality and Environmental

Management Department _____

General Manager : _____

(Koichi Hayashi)

Supplier's Material Declaration

- Asbestos -

Hereby declares that asbestos is not contained the following product(s) including spare parts and supplies.

Company name: Mitsui Engineering & Shipbuilding Co.,Ltd.

Product(s)/Type name;

Main Engine

Turbochargers

Air Cooler

Auxiliary Blower

Remote Control & Electric Governor

Pneumatic Maneuvering System

Tamano, Okayama, Japan
(Place of issue)

19 June 2012
(Date of issue)

Takafumi kimura
 Manager, Service Center
 Technoservice Dept.
Machinery & Systems Headquarters
 (Name, Title and Department)

 (Signature)

Supplier's Material Declaration

- Asbestos -

Ref: A-08250

Company name: Mitui Zosen Machinery & Service, Inc.

Hereby declares that our products have not contained asbestos after
1 January 1995 of the production date.

Object(s) of the declaration: Generator diesel engine set (All type)

3928-3, Haijima-Cho, Akishima-shi,

Tokyo 196-8585, Japan

(Place of issue)

28 June 2012

(Date of issue)

T.Hiramoto / Q.A General Manager

(Name, function)

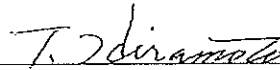

(Signature)

Supplier's Material Declaration

- Asbestos -

Ref.: HSG120628-004-MT

Company name: MIURA Co., Ltd.

Hereby declares that our spare parts and supplies have not contained asbestos after 1st January, 2006 of the delivery date.

7 Horie-cho, Matsuyama, Ehime

JAPAN 799-2696

(Place of issue)

June 28, 2012

(Date of issue)

T. Matsuoka,

Deputy General Manager

Ship Machinery Dept. Promotion Div.

(Name, function)

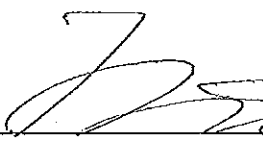
(Signature)



Supplier's Material Declaration

- Asbestos -

Ref: NTS AS 00001 20120625

This document serves as a declaration and confirmation from the manufacturer, Nabtesco Corporation, that asbestos materials are not contained in any assembly component and spare parts after delivery of 1.Sep.2005.

KOBE JAPAN
(Place of issue)

25/06/2012
(Date of issue)

Nabtesco Corporation
Marine Control Systems Company
(Issuer's name)

Akiharu Doi/Manager/Engineering Dept.
(Name, function)

A. Doi
(Signature)

Supplier's Material Declaration

- Asbestos -

Ref.: QH-E12-12-01

Company name: Nakakita Seisakusho Co.,Ltd.

Hereby declares that our products have not contained asbestos after 1st/Jan./1992 of the delivery/production date.

1-1, Fukonominamimachi, Daito city,

Osaka, Japan 〒574-8691

(Place of issue)

15th Jun. 2012

(Date of issue)

N. Kuroki

/Director General Manager of
Quality Assurance Department

(Name, function)



(Signature)

Supplier's Material Declaration

- Asbestos -

Hereby declares that asbestos is not contained the following product(s) including spare parts and supplies.

Company name: Naniwa Pump Mfg. Co., Ltd.

Product(s)/Type name;

All the Products

Osaka Japan
(Place of issue)

2012/6/18
(Date of issue)

TAKAYOSHI OHNO, Senior Managing Director
(Name, Title and Department)

Takano
(Signature)

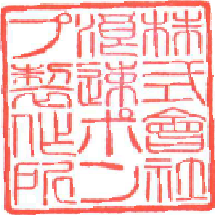

NATIONAL SHIP CHANDLERS (NATAL)

SHIP CHANDLERS

DIRECTORS:

J M JOANNOU

S STYLIANOU

TELEPHONE:

+27 31 205 4221

AFTER HOURS:

+27 31 208 0040

+27 31 303 5400

EMAIL: natship@natship.net

WEBSITE: www.natship.net

1989 (Pty) Ltd

(DURBAN)

REG No. 89/00448/07



"YOUR MARITIME LINK IN AFRICA"

EXPORTERS

ADDRESS:

438 Sydney Road
DURBAN, 4001

P.O. Box 18461
Dalbridge, 4014
SOUTH AFRICA

TELEX: 6-22287 NATDB SA

FAX: +27 31 205 4194
+27 31 205 2220

Asbestos Free Declaration

To Whom It May Concern

This document serves as a declaration from our company NATIONAL SHIP CHANDLERS that asbestos materials are not utilized in any assembly, sub assembly production or distribution of the components, products offered for sale.

Imo Ref. SOLAS CHAPTER ii REGULATION 3-5

MSC 1-CIRC. 1374

MSC 1-CIRC. 1379

MSXC 1-CIRC. 1426//MEPC. 197 (62)

Members of:



CAPE TOWN OFFICES: Tel: +27 21 511 8922/3/4 | Fax: +27 21 511 4990 | Telex: 52-1568 NATCT SA

RICHARDS BAY OFFICES: Tel: +27 35 789 3511/2 | Fax: +27 35 797 3775 | Telex: 6-31386 NATRB

PORT ELIZABETH OFFICES: Tel: +27 41 484 7633/4 | Fax: +27 41 484 7651 | Telex: 24-3382 DEMAS SA

Supplier's Material Declaration

- Asbestos -

Ref: P-12-03

Company name: NICHIAS Corporation

Hereby declares that our products have not contained asbestos after 01/07/2012 of the delivery/production date.

Environmental Control Section

/Technical Division 19/06/2012

(Place of issue) (Date of issue)

Yuko Totsuka / Manager

(Name, function)



(Signature)

Supplier's Material Declaration

-Asbestos-

Hereby declares that asbestos is not contained the following product(s) including spare parts and supplies.

Company name : NIKURA KOGYO CO.,LTD.

Product(s)/Type name ;

• ENGINE ROOM EQUIPMENTS & PIPE FITTINGS

• MARINE EQUIPMENTS & PIPE FITTINGS

• TANKER and GAS CARRIERS FITTINGS

• CLEANING MACHINES

Shizuoka, Japan

(Place of issue)

July/3/2012

(Date of issue)

Mr. TAKERU SATO

Manager

Product Management Department

(Name, Title and Department)

T. Sato

(Signature)



Supplier's Material Declaration

- Asbestos -

Ref.:

Company name: NIPPON CONTROLS Co., Ltd.

Hereby declares that our products have not contained asbestos after 1/1/2006 of the production date.

Tosin Ochanomizu Blding. 7F

2-2-18 Sotokanda

Chiyoda-ku, Tokyo 101-0021

June 18, 2012

(Place of issue)

(Date of issue)

Director Design Section

Hirokazu Sasaoka



(Name, function)

(Signature)

Supplier's Material Declaration

- Asbestos -

Hereby declares that asbestos is not contained the following product(s) including spare parts and supplies.

Company name: The Nippon Corrosion Engineering Co.,Ltd.

Product(s)/Type name;

- Impressed Current Cathodic Protection System (CAPAC)
- Marine Growth Preventing System(MGPS)
- I-CHLON(MGPS+Fe)
- DEFECURON(Cu/Fe)
- DEFECON(Fe)
- DEFOURON(Cu/Al)
- Al Anode
- Zn Anode

Tokyo , Japan
(Place of issue)

June.19.2012
(Date of issue)

Junichi Inoue, QA Gen. Manager
(Name, Title and Department)

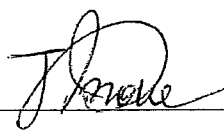
(Signature)

Supplier's Material Declaration

- Asbestos -

Ref.: _____

Company Name: **NIPPON PILLAR PACKING CO., LTD.**

Herby declares that our products have not contained asbestos after 01/07/2012 of the delivery/production date.

Products name; _____

Osaka, Japan _____
(Place of issue) (Date of issue)

Chieko Takii/Manager _____
(Name,function) (Signature)

Supplier's Material Declaration

- Asbestos -

Hereby declares that asbestos is not contained the following product(s) including spare parts and supplies.

Company name: Nippon Pusnes Co., Ltd.

Product(s)/Type name:

Windlass

Mooring winch

Pump station

Pump unit

Tokyo, Japan

(Place of issue)

June 18, 2012

(Date of issue)

Masamitsu Shimizu

General manager

Technical & QA Department

(Name, Title and Department)



(Signature)

2010年(平成22年)2月9日

石綿(アスベスト)不使用証明書

<< ガスケット編 ①ソフトガスケット >>

日本バルカー工業株式会社

弊社が製造販売する下記製品はすべて非石綿材料で構成され、石綿を一切使用していません。

ソフトガスケット	
ブラックハイパー	GF300、SF300
ホワイトハイパー	GE200
ブラックスーパー	6502
ノンアスジョイントシート・ ガスケット	6500、6500AC、6500AE
	6501
	6503、6503AC、6503AE
	6506
	6471
	VND605B
	VND619BK
	VND627IK
	VND629ET
	VND639A
	VND657K
	VND667
	VND668
ふっ素樹脂ガスケット	N7030
	N7031
	N7035
	7010、7010EX
	7020
	7026
	7GS62A、7GS62N
	7GS64N
	7GS66A、7GS66N
	7GP61、7GP66
	7204
膨張黒鉛ガスケット	VF-30
	VF-35E
	VFT-30
	VFT-35E
	VF-50
	VF-60
	VF-70
合成ゴムシート・ガスケット	2000、2010
	4000、4010
	5000、5010
FRシート・成形品	27000
インフラートシール	2045
	4045
	5045
オイルシート	681、681PG
バルカテックスガスケット	N214
	N314
テープシール	20

以上

Declaration on Non-use of Asbestos

We, Nippon Valqua Industries, Ltd., hereby duly declare that each product listed below fully consists of asbestos-free materials:

Soft Gaskets

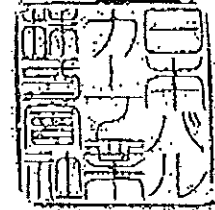

Name / Description	VALQUA No.	Asbestos use rate
<i>BLACK HYPER</i>	GF300	0 %
<i>BLACK SUPER</i>	8502	
Compressed Non-Asbestos Sheet	6500, 6500 AC, 6500 AE, 6503, 6503 AC	
Fluorocarbon Resin Gasket	N7030, N7031, N7035, 7010, 7010 EX, 7020, 7028, 7GS62A, 7GS62N, 7GS64N, 7GS66A, 7GS66N, 7GP61, 7GP66	
Expanded Graphite Gasket	VF-30, VF-35E, VFT-30, VFT-35E, VF-50, VF-60, VF-70	
Rubber Gasket	2000, 2010, 4000, 4010, 5000, 5010	
FR Sheet	27000	
INFLATE Seal	2045, 4045-6045	
VALQUATEX Gasket	N214, N314	
Tap Seal	20	

Note: Possible content as an impurity (if for instance, dust that has dispersed in air.)

NIPPON VALQUA INDUSTRIES, LTD.



NOBU MARINE PTE. LTD.
(SHIPPING AGENCY AND MARINE SUPPLIES)



SINGAPORE OFFICE:
BLK N, 81 PANDAN LOOP
SINGAPORE 128292
TEL: (65) 6273 5611
FAX: (65) 6273 2264
EMAIL: common@nobumarine.com.sg
GST Reg. No.: M2-0075567-7
Co. Reg. No. 198700639G

DUBAI OFFICE: (U.A.E.)
SAIFEE NOBU MARINE LLC
DUBAI INVESTMENT PARK
PLOT NO. 598-755
P.O. BOX 3316, DUBAI U.A.E.
TEL: 971-4-812-4444/45
FAX: 971-4-812 4486
EMAIL: nobu@saifeeship.com
EMAIL: saiffee@saifeeship.com

ROTTERDAM OFFICE: (HOLLAND)
NOBU MARINE LTD
HARBOUR NO. 2330
VAN MAASDIJKWEG 56-60
3088 EG ROTTERDAM, HOLLAND
TEL: +31-10-429-25-70
FAX: +31-10-429-73-09
TELEX: 28740 ships.nl
EMAIL: shipstores@wxss.nl

DATE: 11 May 2016

To Our Valued Customers

Dear Sir,

RE: SUPPLIER'S MATERIAL DECLARATION –NON ASBESTOS

Hereby declares that our product (ship stores & spares) have not contained asbestos after **JANUARY 2014** of the delivery/production date by Nobu Marine Pte Ltd/Nobu Marine Ltd.

Thank you.

Yours Faithfully,

(NOBU MARINE PTE LTD)
MR. TAUFER
ASST. OPS MANAGER

S/NO: 01



NOBU MARINE PTE. LTD.
(SHIPPING AGENCY AND MARINE SUPPLIES)



ISSA NO: SG0049

SINGAPORE OFFICE:
BLK N, 81 PANDAN LOOP
SINGAPORE 128292
TEL: (65) 6273 5811
FAX: (65) 6273 2264
EMAIL: common@nobumarine.com.sg
GST Reg. No.: M2-0075567-7
Co. Reg. No. 198700639G

DUBAI OFFICE: (U.A.E.)
SAIFEE NOBU MARINE LLC
DUBAI INVESTMENT PARK
PLOT NO. 598-755
P.O. BOX 3316, DUBAI U.A.E.
TEL: 971-4-812-4444/45
FAX: 971-4-812 4486
EMAIL: nobu@saifeeship.com
EMAIL: saiffee@saifeeship.com

ROTTERDAM OFFICE: (HOLLAND)
NOBU MARINE LTD
HARBOUR NO. 2330
VAN MAASDIJKWEG 56-60
3088 EG ROTTERDAM, HOLLAND
TEL: +31-10-429-25-70
FAX: +31-10-429-73-09
TELEX: 28740 ships.nl
EMAIL: shipstores@wxs.nl

Supplier's Material Declaration
- Asbestos -

Ref.: NOBU/201207-01

Company name: NOBU MARINE PTE LTD, BIK N, No.81 Pandan loop, S128292.

Hereby declares that our products have not contained asbestos after **01/JULY/12** of the delivery/production date.

SINGAPORE
(Place of issue)

01/JULY/2012
(Date of issue)

Mr. ALVIN POH / DIRECTOR
(Name, function)

W.K. Poh
(Signature)



8/8/12

TO CUSTOMERS

Date : 6 JULY 2012

Document No : Q - 1 2 0 6 2 5 - T 1

Sub : Asbestos-laden material

We, Okumura Engineering Corp have not used asbestos-laden material for all products of flowing chart since April 2006.

CHART

Valve name	Butterfly valve	Knife gate valve	Pinch valve	Check valve	Storm valve
Model	6 0 2 A / 6 0 3 A	3 3 6 J	7 0 2	1 1 0 Z	1 0 2 S
	6 1 2 X / 6 1 5 X	—	7 0 3	1 2 0 Z	1 0 2 L
	6 0 6 K / 6 0 6 F	—	7 0 4	1 1 1 S	1 0 3 S
	6 1 6 J	—	—	1 2 1 S	1 0 3 L
	6 1 8 H	—	—	—	—
	6 2 2 H	—	—	—	—
	5400 / 5410 / 5420	—	—	—	—

OKUMURA ENGINEERING corp.

446-1,Ohtani,Hino-cho,Gamo-gun,Shiga 529-1608

Signature



Kenji Tani

Manager

Quality Assurance Department



OSAKA BLOWER MFG. CO., LTD.

Supplier's Material Declaration
-Asbestos-

Ref.: _____

Company name: OSAKA BLOWER MFG. CO., LTD.

We hereby declare that our products have not contained asbestos since delivery/production date (1.1.1990)

Japan Osaka
(Place of issue)

(Date of issue)

fan parts
(Name,function)

G. Shirota
(Signature)

3-35, Takeshima 5-Chome,
Nishiyodogawa-Ku,
Osaka 555-0011, Japan

OSAKA BOILER
OSAKA BOILER MFG. CO., LTD.

TEL: +81-6-6471-2451
FAX: +81-6-6474-1740
marine@osakaboiler.co.jp

Supplier's Material Declaration - Asbestos -

Ref.: TD-1938

Company name: OSAKA BOILER MFG. CO., LTD.

Hereby declares that our products have not contained asbestos after end of August, 2005 of the delivery date.

3-35, 5-Chome, Takeshima,
Nishiyodogawa-ku, Osaka, Japan
(Place of issue)

20, June, 2012
(Date of issue)

Isao Konishi
General Manager of Engineering Dept.
(Name, function)

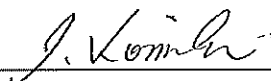
(Signature)



PACIFIC WEST
Ship Supply Co.(L.L.C.)DUBAI

Supplier's Material Declaration ∞ Non Asbestos ∞

PACIFIC WEST SHIP SUPPLY CO. LLC. declares that our

Products and packing materials do not

Contains any asbestos.

HOMI ELAVIA
(GENERAL MANAGER)
(+97150 6247750)



PACIFIC WEST SHIP SUPPLY CO. LLC.

P.O. BOX : 48676,

DUBAI (U.A.E.)

TEL: +9714 347 2688,

FAX: +9714 347 3305,

Email: pacwest@emirates.net.ae / office@pwships.com

Website: www.pwships.com

"An ISO 9001:2008 Certified Company"



ISO 9001:2008
Reg. No: RQ971/6359

P.O. Box 48676 Dubai, U.A.E.
Tel.: 971- 4 -3472688, Fax: 971- 4 - 3473305
E-mail: pacwest@emirates.net.ae



RMS Marine Service Company Ltd.

Tel: +86-21-50171617 Fax: +86-21-65380899 www.rmsmarineservice.com
rms@rmsmarineservice.com for stores/provisions; spare@rmsmarineservice.com for spares;
technical@rmsmarineservice.com for safety/technical; logistics@rmsmarineservice.com for spare transit



To: Grindrod Shipping Pte. Ltd

May. 2016

Declaration for Asbestos Free products

We, herewith, confirm that we only have been dealing with Asbestos Free products. Those are not only for our own branded/produced products but also for the products which we have been buying from domestic supplier. (Overseas supplier as well)

Outline of our products

1. General Store
2. Valve
3. Packing
4. Materials for packing (Carton box & Tape)
5. Warming tape (Ceramic Ribbon, Ceramic Cloth)
6. Spare parts

We do not have any material which contains asbestos also for other products such as Joint Sheet, Adhesive products, Lubricant products, etc.

We can prepare Non-Asbestos Confirmation Certificate upon request.

Customer Relationship Manager

RMS MARINE SERVICE COMPANY LTD

PRODUCT STEWARDSHIP BOARD (PSB)

Policies

Asbestos:

1. Rolls-Royce continues to eliminate asbestos from its products. The remaining applications critical to aerospace safety will be eliminated at least one year before the EU regulatory prohibition date of 31/12/2003 for such applications. This is to avoid international trading infringing regional legislation. Where asbestos is critical to weapons systems integrity, exemptions to prohibition will be sought through, and maintained with, the relevant Defence or regulatory authorities. All other applications are prohibited.
2. Rolls-Royce requires that, unless critical to weapons systems integrity or aerospace safety, externally designed items must now be free of asbestos.
3. Rolls-Royce recommends the replacement of installed asbestos components at the first appropriate overhaul interval following the validation of alternatives.

Cadmium:

Cadmium is prohibited in aerospace designs by aerospace Joint Design Standards 002. Some components in projects which post-date JDS 002 have incorporated cadmium through the read-across of designs. The policy is to identify and substitute. Where technically and cost effective, older projects should also be substituted out.

Energy, Marine and Defence Businesses will comply other than where customer specifications demand cadmium. Standard parts will be addressed through international industry action.

Where cadmium is critical to weapons systems integrity, exemptions to prohibition will be sought through, and maintained with, the relevant Defence or regulatory authorities. Rolls-Royce requires that, unless critical to weapons systems integrity or aerospace safety, externally designed items must now be free of cadmium.

The Product Stewardship Board must be informed of all remaining uses of Cadmium, together with the reasons for continued use.

All other applications are prohibited.

Vapour degreasing:

The company Health, Safety and Environmental Manual of Standards (Standard EN/Q.06) requires that vapour degreasing will be phased out unless technically essential. Where it must be used, fully enclosed plant

designs must be phased in.

Beryllium:

Beryllium alloys will not be incorporated into company designs unless critical to the technical achievement of a project. Alloys will not be included in material selectors. Where a case is to be made for the use of beryllium, 12 criteria have to be met and the justification decided by the Product Stewardship Board. The criteria are detailed in the UK Health, Safety and Environmental Manual of Standards (Standard HS/D.10G). (This will be more widely available via the Corporate HS&E Infonet site in 2002.)

PSB policies, issue 2 Sept 2007

Supplier's Material Declaration

- Asbestos -

Ref.: VAT Reg No.DE811755553

Company name:

RWO GmbH

Thalenhorststrasse 15A

28307 Bremen, Germany

Hereby declares that our products have not contained asbestos after 01/01/01 of the /production date.

Bremen, Germany

(Place of issue)

27/06/12

(Date of issue)

Mr. Pekka Pohjanen, Sales Manager

(Name, function)

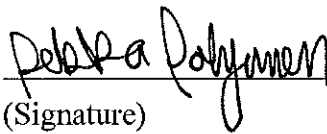

(Signature)

Supplier's Material Declaration

- Asbestos -

Ref.: 1600/bok

Company name: SAACKE GmbH

Hereby declares that our products have not contained asbestos after 31/12/1982 of the production date.

Bremen, Germany
(Place of issue)

27th June 2012
(Date of issue)

Dr. Katharina Boeck, Project Manager
(Name, function)

K. Boeck
(Signature)

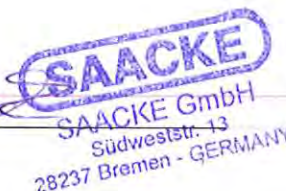

Supplier's Material Declaration

- Asbestos -

SAGINOMIYA SEISAKUSHO, INC.

hereby declares that asbestos is not contained in the following product(s) including spare parts and supplies delivered on and after 07/01/2012.

Product(s)/Type name:

All Products

Including but not limited to:

Pressure switch, Temperature switch, F. O. Viscorator,

Flow switch, Humidity switch, Thermostat, Solenoid valve,

Pneumatic 3-way valve, Safety valve, Electric control valve,

Relief valve, Expansion valve, Pressure checker,

Temperature Sensor, Control valve motor and Pressure sensor.

(Place of issue)

Saitama, Japan

(Date of issue)

July 09, 2012

(Name)

Akinori Furukoori

Manager of Quality Management Section

(Signature)

A. Furukoori



CERTIFICATE

THE ASBESTOS OF PRODUCT IS FREE.

(Remark : Since Jan. 2006~)

SANWA CO.,LTD.

Quality Control Section

m. okamoto

April 12, 2011

証 明 書

弊社製品にはアスベスト類は使用していません。

(2006年1月より)

株式会社SANWA

品質管理課

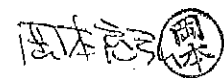

April 12, 2011

Supplier's Material Declaration

- Asbestos -

Ref.: SD_SASAKURA_20120621

Company name: SASAKURA ENGINEERING CO., LTD.

Hereby declares that our products have not contained asbestos after January 1, 1989 of the delivery date.

OSAKA, JAPAN

(Place of issue)

June 21, 2012

(Date of issue)

Yoshihiro Yamada

Manager of Marine Engineering Sect.

(Name, function)

(Signature)



Supplier's Material Declaration

- Asbestos -

Ref.: Scanjet tank cleaning machines_____

Company name: Scanjet Marine AB

Hereby declares that our products have not contained asbestos after 2001-02-26 of the production date.

Göteborg

(Place of issue)

2012-06-28

(Date of issue)

Johan Helamb / Project Manager

(Name, function)



(Signature)

Sj scanjet
Scanjet Marine AB
P.O. Box 2
SE-275 21 SJÖBO
Sweden

Supplier's Material Declaration

- Asbestos -

Ref: SEM-ASBESTOSFREE-DECLARE/BNWAS

Company name: SEAMATE INC.

Hereby declares that our products (BNWAS MODEL: SMC-PLC-001) have not contained asbestos after 1st October, 2011 of the product date.

1-20-16, Nakahiro, Nishi-ku,
Hiroshima-city, 733-0012, Japan
TEL :+81-82-235-2351
FAX :+81-82-235-2352

27th June, 2012

(Place of issue)

(Date of issue)

T. Ueda / Quality Assurance Sec.



(Name, function)

(Signature)

Supplier's Material Declaration

- Asbestos -

Hereby declares that asbestos is not contained the following product(s) including spare parts and supplies.

Company name: Shinko Ind. Ltd.

Product(s)/Type name;

Centrifugal Pump, Reciprocating Pump

Steam Turbine

Hiroshima, Japan
(Place of issue)

June 22, 2012
(Date of issue)

A. Okinaga, Manager
Quality System Section
(Name, Title and Department)

A. Okinaga
(Signature)

Supplier's Material Declaration

- Asbestos -

To : Kunimori Engineering Works Co., Ltd.

Ref. : SHW12 CF 0707

Company name : SHOWA INDUSTRIAL CO., LTD.

CERTIFICATE

Hereby declares that our products have not contained asbestos.

3-4-5 Hirotagaya Kure City

Hiroshima Japan

(Place of issue)

6 / July / 2012

(Date of issue)

Sales Division

Toshitsugu Unehara

(Name, function)

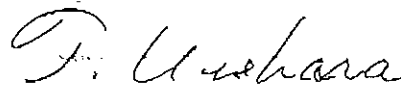

(Signature)

Supplier's Material Declaration

- Asbestos -

Hereby declares that asbestos is not contained the following product(s)

including spare parts and supplies.

Company name: Starlite Co., Ltd.

Product(s)/Type name;

『Non-metallic rudder bearing material』

● Starlite "Red" #11630

● Starlite "Mostar" #13630

● Starlite "non-As. Selb" #12673

2222, Kamitoyama, Ritto-shi, Siga,
520-3004, Japan

(Place of issue)

12 July 2012.

(Date of issue)

Yoshiharu Okazaki,
Advanced Products Plant Manager

(Name, function)



(Signature)

STX Marine Service Co., Ltd.

50-3, Seoungju-dong, Sungsan-gu, Changwon, Korea 642-120
Engine Parts Marketing Team.
Web site: www.stxmarineservice.co.kr

ASBESTOS FREE CERTIFICATE

for

All STX Engines

Maker : STX Engine co.,Ltd
Equipment : Diesel Generator Engine

We, STX Marine Service Co., Ltd. Hereby confirm that asbestos-free materials have been used only on the above mentioned products which are installed on the vessel in question.

Regards,

S. J. Choi
Deputy G.Manager of Parts Sales Team
STX Service Europe B.V.
Tel : +31 (0)88 451-2002
e-mail : sjchoi@onestx.com
web : www.stxmarineservice.co.kr



Date: December 01, 2011

Supplier's Material Declaration

- Asbestos -

Hereby declares that asbestos is not contained the following product(s) including spare parts and supplies.

Company name: Suction Gas Engine MFG. CO., LTD.

Product(s)/Type name:

Set of spare parts for Main air compressor/ Type TCAX and TCWX

Set of spare parts for Emergency air compressor/ Type TCAX and TCWX

Set of spare parts for LPG compressor/ Type HO-20

Tokyo, Japan
(Place of issue)

Jun 21, 2012
(Date of issue)

Mr. Makoto Takeuchi
President
(Name, Title and Department)

M. Takeuchi
(Signature)



Supplier's Material Declaration

- Asbestos -

Ref.: ASB-120625-I

Hereby declares that asbestos is not contained the following product(s)

* manufactured on or after 01/01/1990

~~* delivered on dd/mm/yy~~

including spare parts and supplies.

*: as delete appropriately

Company name: SUNFLAME CO., LTD.

Product(s)/Type name;

Incinerator

Uji, Kyoto, JAPAN

(Place of issue)

25/06/2012

(Date of issue)

K. OKUMURA, Manager
Q.A. Department

(Name, function)



(Signature)

Supplier's Material Declaration
- Asbestos -

Ref.: ASB-120625-B

Hereby declares that asbestos is not contained the following product(s)

* manufactured on or after 01/08/2005

~~* delivered on dd/mm/yy~~

including spare parts and supplies.

*: as delete appropriately

Company name: SUNFLAME CO., LTD.

Product(s)/Type name;

Oil Burning Apparatus

Uji, Kyoto, JAPAN

(Place of issue)

25/06/2012

(Date of issue)

K. OKUMURA, Manager
Q.A. Department

(Name, function)



(Signature)



19 November 2012

Ref: SM/AST/JL/2012

**For the attention of Jacqy Lim
APEX SEALING TECHNOLOGIES PTE LTD**

To Whom It May Concern,

RE: The analysis of "Superlite GP 150" for the presence of asbestos under polarised light microscopy (PLM) with dispersion staining.

Upon receipt of the above sample, Acorn Analytical Services Limited, which is an UKAS Accredited Testing Laboratory, undertook analysis for the presence of asbestos. The analysis process involves an initial inspection using Binocular Microscopy, and fibre confirmation using Polarised Light Microscopy (PLM) with Dispersion Staining. The sample was broken up and thoroughly inspected by the analyst under laboratory conditions, in accordance with our UKAS Accreditation.

The results from the bulk analysis confirmed that **Superlite GP 150** is an **ASBESTOS FREE** product.

Description of Terminology	
Amosite	Brown Asbestos
Chrysotile	White Asbestos
Crocidolite	Blue Asbestos
Non Detected	Asbestos Free

The accompanying bulk certificate (**PRN7853**) follows this letter.

Should you need further assistance, please contact your vendor accordingly.

Yours sincerely

A handwritten signature in black ink, appearing to read "SMcGlone", is positioned above the typed name.

Acorn Analytical Services
Stephen McGlone
Operations Director

Certificate Of Bulk Analysis For Asbestiform Material

Client:	<input type="text" value="Apex Sealing Technologies PTE Ltd"/>	PRN No:	<input type="text" value="PRN7853"/>
Contact:	<input type="text" value="Jacquerine Lim"/>	Site:	<input type="text" value="Superlite GP 150"/>
Client Address:	<input type="text" value="No.23 Pioneer Sector Singapore 628431"/>		
Contact No:	<input type="text" value="6266 4388"/>		
Sample Taken by:	<input type="text" value="Not Specified"/>	OF:	<input type="text" value="Not Specified"/>
Date taken:	<input type="text"/>	Received Date:	<input type="text" value="16/11/2012"/>
		Analysis Date:	<input type="text" value="16/11/2012"/>

CD61 Issue 1 Revision 4 09/11/10

Analysis Details

Samples Analysis By:	<input type="text" value="Jonathan Parker"/>	Analyst Signature:	<input type="text" value="Signature"/>
Position:	<input type="text" value="Environmental Consultant"/>		
Issued by:	<input type="text" value="Jonathan Parker"/>	Issued by Signature:	<input type="text" value="Signature"/>
Issued by position:	<input type="text" value="Environmental Consultant"/>		

Analysis Results

Sample Ref	Material Type	Sample Details	Result
BS21376	Gasket	Superlite GP 150	Non detected

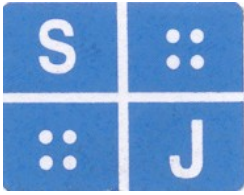

Superlite[®]

SUPERLITE ASBESTOS FREE

GP-150

Basis

Gasket material based on organic fibre with NBR binder.

Application

General purpose grade suitable for low pressure steam, water, oils, fuels and inert gases for low stress conditions.

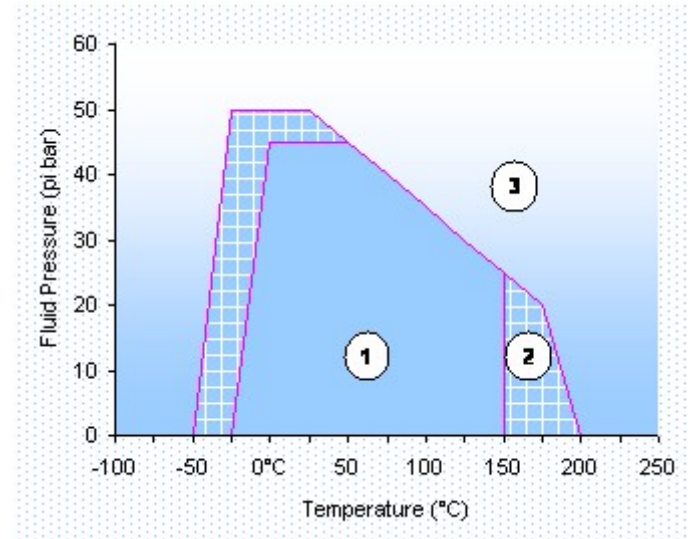
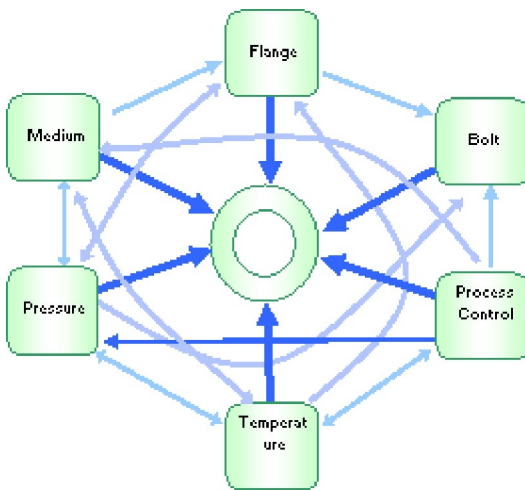

Factors affecting on the gasket

The suitability of a gasket material for an application is dependent upon a multiplicity of factors as shown in the above digram. Max. temperature and pressure values can not define the suitability for application. It is always advisable to consider these factors when selecting a material for a given application.

Areas of application

- 1) This area refer , the gasket material is normally suitable subject to chemical compatibility.
- 2) This area refer, the gasket material may be suitable but a technical support is recommended.
- 3) This area refer, do not install the gasket without technical evaluation.

Dimensions of the standard sheets

1500 mm X 1500 mm, 1500 mm X 2250 mm, 1500 mm x 4500 mm

Specifications : ASTM F 104 F 712132E43 A9 B6 M4

Technical data

All data are typical values and refer to sheet thickness of 1.5 mm

	Specification	
Max. Peak Temperature		200°C
Max. Operating Temperature		150°C
Max. Operating Pressure		50bar
Density	ASTM F 1315	1.8g/cm ³
Compressibility	ASTM F 36 J	8%
Recovery	ASTM F 36 J	50%
Tensile Strength	ASTM F 152	7N/mm ²

Creep Relaxation	ASTM F 38 B	40%
Gas Sealability	ASTM F 37 B	< 1.0ml/min.
Thickness Increase	ASTM F 146	
ASTM oil no.3 (5h, 150°C)		10%
ASTM Fuel B (5h, 23°C)		10%
Water (5h, 100°C)		6%
Weight Increase	ASTM F 146	
ASTM oil no.3 (5h, 150°C)		15%
ASTM Fuel B (5h, 23°C)		15%
Water (5h, 100°C)		5%

All information and recommendations given in this brochure are correct to the best of our knowledge. However, in view of the wide variety of possible installation and operating conditions one cannot draw the final conclusion in all application cases regarding the behaviour in a gasket joint. Therefore, information can only serve as a guideline.

Declaration of Asbestos free-products

This document serves as a Declaration from the Supplier,

SYMSCO Co., Ltd., Korea

that asbestos materials have not been utilized in any products

from this company since 31st May 2010.

Busan, Korea

(Place of issue)

Mr. H. J. Yoon
President

(Name, Title)

03 Jul 2012

(Date of issue)

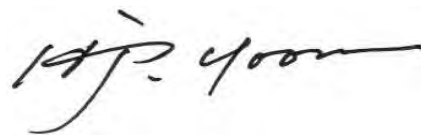

(Signature)

Supplier's Material Declaration

- Asbestos -

Ref: 120614TMD01

Company name: TAIKO KIKAI INDUSTRIES CO.,LTD.

Hereby declares that our marine products have not contained asbestos after
1/September/2006 of the delivery date.

209-1 Shimotabuse, Tabuse-cho,
Kumage-gun, Yamaguchi-Pref.
JAPAN 742-1598

(Place of issue)

June 14, 2012

(Date of issue)

Yoshiaki Yamada
Managing Director
General Manager of Marine Division
(Name, function)

(Signature)

Supplier's Material Declaration

- Asbestos -

Ref: 120618-01

Company name: TAIYO ELECTRIC CO., LTD. GUNMA PLANTS

Hereby declares that our products have not contained asbestos after 01/10/87 of the production date.

330-5 YATTAJIMA-MACHI

ISESAKI-CITY GUNMA JAPAN

(Place of issue)

2012/06/18

(Date of issue)

Y.SHIBATA

Manager of Designing Section

(Name, function)

Y. shibata

(Signature)

Supplier's Material Declaration

- Asbestos -

Ref.: SD-TAIYO-20120625

Company name: TAIYO ELECTRIC CO.,LTD. GIFU PLANTS

Hereby declares that our products have not contained asbestos after 01/04/90 of the production date.

18.KISARAGI-CHO KASAMATSU-CHO,

HASHIMA-GUN GIFU JAPAN

(Place of issue)

2012/06/25

(Date of issue)

Ichiro Amano, Technical Dept.

(Name, function)

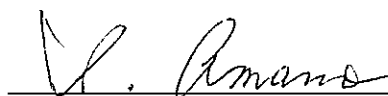

(Signature)

平成 24 年 6 月

取引先各位

〒652-0804
神戸市兵庫区塚本通 1 丁目 2 番 10 号
株式会社 高松

代表取締役 中本 典之

アスベストを含む材料を使用していない旨の宣言書

拝啓 貴社ますますご盛栄のこととお喜び申し上げます。

平素は格別のご高配を賜り、厚くお礼申し上げます。

弊社では 2007 年以降アスベスト製品は使用しておらず

今現在支給するパッキン類、ラギング材、ガスケット類、ブレーキライニング等

全ての物品はアスベストを含む材料を使用していないことをここに宣言いたします。

敬具

2010年(平成22年)2月9日

石綿(アスベスト)不使用証明書

<< ガスケット編 ①ソフトガスケット >>

日本バルカー工業株式会社

弊社が製造販売する下記製品はすべて非石綿材料で構成され、石綿を一切使用していません。

ソフトガスケット	
ブラックハイパー	GF300, SF300
ホワイトハイパー	GE200
ブラックスーパー	6502
ノンアスジョイントシート・ ガスケット	6500, 6500AC, 6500AE
	6501
	6503, 6503AC, 6503AE
	6506
	6471
	VND605B
	VND619BK
	VND627IK
	VND629ET
	VND639A
	VND657K
	VND667
VND668	
ふっ素樹脂ガスケット	N7030
	N7031
	N7035
	7010, 7010EX
	7020
	7026
	7GS62A, 7GS62N
	7GS64N
	7GS66A, 7GS66N
	7GP61, 7GP66
	7204
膨張黒鉛ガスケット	VF-30
	VF-35E
	VFT-30
	VFT-35E
	VF-50
	VF-60
	VF-70
合成ゴムシート・ガスケット	2000, 2010
	4000, 4010
	5000, 5010
FRシート・成形品	27000
インフラートシール	2045
	4045
	5045
オイルシート	681, 681PG
バルカテックスガスケット	N214
	N314
テープシール	20

以上

環境管理資料

御中

ニチアス株式会社
 技術本部 環境管理室
 〒105 東京都港区芝大門1丁目1番26号
 電話 03-3433-7248

弊社「ノンアスベストジョイントシート」の無石綿証明に関する件

貴社より、御問合わせの標記の件に関し、下記に御回答申し上げます。

記

下記弊社「ノンアスベストジョイントシート」は、製造開始以来、石綿（アスベスト）は一切使用していないことを、ここに証明いたします。

- ・T#1120 クリソトップ
- ・T#1120-LN クリソトップ LN
- ・T#1912 NAジョイントシート
- ・T#1914 NAジョイントシート
- ・T#1915 NAジョイントシート
- ・T#1915-B NAジョイントシート
- ・T#1916 NAジョイントシート
- ・T#1916-N NAジョイントシート
- ・T#1918 NAジョイントシート
- ・T#1923 NAジョイントシート
- ・T#1927 クリソルイー
- ・T#1935 NAジョイントシート 1935
- ・T#1938 クリソルUF
- ・T#1990 NAジョイントシート
- ・T#1991 クリソートR
- ・T#1991-NF クリソルNF
- ・T#1992-B NAジョイントシート
- ・T#1992-S NAジョイントシート
- ・T#1993 クリソルスーパー
- ・T#1995 クリソルアラウン
- ・T#1995-SK クリソルアラウン水栓金具用
- ・T#1995-TOS クリソルアラウン
- ・T#1995-B NAジョイントシート
- ・T#1995-G NAジョイントシート
- ・T#1995-H NAジョイントシート
- ・T#1995-M クリソルブルー
- ・T#1995-N NAジョイントシート
- ・T#1995-W クリソル赤ワト
- ・T#1995-S NAジョイントシート
- ・T#1996 NAジョイントシート
- ・T#1997 NAジョイントシート
- ・T#1997-B NAジョイントシート
- ・T#NU1120 NUクリソトップ
- ・T#NU1993 NUクリソルスーパー

以上

整理番号	P-11-09	承認		照査		担当				
作成年月日	平成23年11月1日									

Supplier's Material Declaration

- Asbestos -

Ref.: 20120618

Company name: TANABE PNEUMATIC MACHINERY CO.,LTD.

Hereby declares that our products have not contained asbestos after 31/03/2006 of the production date.

1-1 , Kawanishi , Komaki-City ,

Aichi , JAPAN 485-0045

(Place of issue)

18 / 06 / 2012

(Date of issue)

Director , Factory Manager

Norimasa Izumi

(Name, function)

N. Izumi

(Signature)

Supplier's Material Declaration

- Asbestos -

Ref.: _____

Company name: TeamTec AS

Hereby declares that our products have not contained asbestos after dd/mm/yy of the delivery/production date.

Tvedestrand, Norway

(Place of issue)

TeamTec AS
P.O. Box 203
4902 Tvedestrand
Norway

Anita Kirsebom, Product Manager

(Name, function)

28.06.2012

(Date of issue)

Anita Kirsebom

(Signature)

Declaration of the Absence of Asbestos in the Manufacture or Packaging of Materials, Components, Products or Systems installed in and offered for ABS classified vessels, facilities and mobile offshore drilling units

Company Name: TECHCROSS Inc.

Materials, Components, Products or Systems for

Shipyard: Tianjin Xingang Shipbuilding Heavy Industry Co., Ltd

Hull Number(s): NB008-1/2

Drawing Number: MTM0081/82

Drawing Title: BWMS drawing for approval (ECS-2000B X 1set)

The undersigned, recognizing that, in accordance with;

1. ABS Rules, all materials, components, products and systems must be suitable for installation on ABS classified vessels, facilities and Mobile Offshore Drilling units (MODUs) and that the ABS Rules now prohibit the installation of materials containing asbestos* on ABS classed vessels (both new construction and existing vessels),
2. International Maritime Organization (IMO) Resolution MSC.282 (86), adopting SOLAS Reg. II-1/3-5.2, the installation of materials containing asbestos* on all ships (both new construction and existing vessels) is prohibited after 1 January 2011,
3. the IMO MODU Code 2009, (which is intended to apply to mobile offshore drilling units the keels of which are laid or which are at a similar stage of construction on or after 1 January 2012), asbestos* is not to be used;

warrants that the aforementioned company has not and will not present a material, component, product or system containing asbestos* for the subject vessel, facilities or mobile drilling offshore unit.

Department/Section

Engineering Team 1

Signature

S.H.LEE, Assistant Manager

[Print Name, Title]

Date

2012. 09. 26

* "asbestos" comprises any of the following six mineral names and associated "Chemical Abstracts Service" (CAS):

1. Actinolite CAS 77536-66-4
2. Amosite (Grunerite) CAS 12172-73-5
3. Anthophyllite CAS 77536-67-5
4. Chrysotile CAS 12001-29-5
5. Crocidolite CAS 12001-28-4
6. Asbestos Tremolite CAS 77536-68-6

Supplier's Material Declaration

- Asbestos -

Ref.: E 4 1 3 7 5

Company name: TEIKOKU MACHINERY WORKS, LTD.

Hereby declares that our Marine Pumps and parts have not contained asbestos after 1st/Dec./2005 of the ~~delivery~~/production date.

515-0041, 3456, UEGAWA-CHO,
MATSUSAKA, MIE PREF. JAPAN

(Place of issue)

4th July 2012

(Date of issue)

Yasuo Yokota / Director
Quality Control Department

(Name, function)

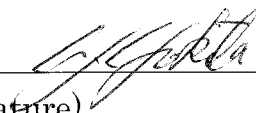

(Signature)



TENTOSHI MARINE SERVICES CO., LTD.
Committed to Reliability

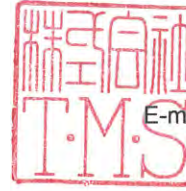

Green Park Bldg. 210
Uenokouen 18-8, Taito-ku,
Tokyo: 110-0007, Japan
Tel: 03-5834-7831
Fax: 03-5834-7832
E-mail: sales@tentoshims.co.jp
<http://www.tentoshims.co.jp>

Dated: 23rd May 2016

Supplier`s Material Declaration

- Non Asbestos -

As per various maker advised, hereby declares that our supplies marine products do not contain any asbestos.

A handwritten signature in black ink, appearing to read 'Md. Asrafull Alam', written over a horizontal line.

Md. Asrafull Alam

Supplier's Material Declaration

- Asbestos -

Ref.: _____

Company name: TOMOEVALVE CO., LTD.

Hereby declares that our products have not contained asbestos after
31th. December 1998 of the delivery/production date.

OSAKA, JAPAN
(Place of issue)

22nd. June, 2012.
(Date of issue)

WEST JAPAN SALES DEPT. 2
YOSHIHITO MIYAMOTO
(Name, function)

Sales Department Y. Miyamoto
(Signature)

Declaration of Asbestos-free

アスベスト不使用宣言

Hereby declares that asbestos is not contained the following products.

以下の製品にはアスベストが含まれていないことをここに宣言する。

Issuer's name: Tortoise Engineering Co.,Ltd.
(発行者の名称) トータスエンジニアリング株式会社

Issuer's address: 700, Kitagawara, Masaki-cho, Iyo-gun, EHIME PREF., JAPAN
(発行者の住所) 愛媛県伊予郡松前町北川原 700

Object(s) of the declaration: All products manufactured after 01/04/2006.
(宣言の対象) 2006年4月1日以降に製造された全ての製品
Including spare parts and supplies.
予備部品、支給品を含む

Ehime, JAPAN

(Place of issue)

(発行場所)

22/06/2012

(Date of issue)

(発行日)

Manabu Izumi, Quality Control Team Manager

(Name, function)

(責任者の氏名、役職)

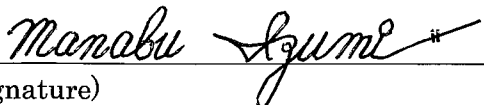

(Signature)

(署名)

Supplier's Material Declaration

- Asbestos -

Ref.: _____

Company name: TRATEC LTD.
PRODUCT:ANTI-FOULING SYSTEM

Hereby declares that our products have not contained asbestos after 01/01/1980 of the delivery date.

1-43-13, Asagaya-kita, Suginami-ku,

Tokyo, Japan 166-0001

28-06-2012

(Place of issue)

(Date of issue)

Kiyofumi Tsuji

(Name, function)

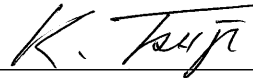

(Signature)

Supplier's Material Declaration

- Asbestos -

Ref.: _____

Company name: TRATEC LTD.

PRODUCT : ICCP SYSTEM
PROPELLER SHAFT GROUNDING SYSTEM

Hereby declares that our products have not contained asbestos after
1ST JUL 1994 of the delivery date.

1-43-13 ASAGAYA-KITA, SUGINAMI-KU

TOKYO, JAPAN. 166-0001

(Place of issue)

28TH JUN 2012

(Date of issue)

O. YAMAZAKI

(Name, function)



(Signature)



TRIBOMAR GmbH Biedenkamp 3e D-21509 Glinde

TRIBOMAR GmbH

Biedenkamp 3e
D-21509 Glinde
Tel.: +49-40 73091399-0
Fax: +49-40 73091399-33
info@tribomar.com
www.tribomar.com

Steuernr.: 46/764/01623

To whom it may concern

ASBESTOS-FREE DECLARATION According to SOLAS regulation II-1/3-5

We hereby declare that all materials delivered by TRIBOMAR GmbH do not contain asbestos or asbestos containing materials or components and are therefore completely free of asbestos in accordance with SOLAS regulation II-1/3-5.

Date: 11.05.2016

Place: Hamburg, Germany

Jurgen Krebs
Name

TRIBOMAR GmbH
Biedenkamp 3e / D-21509 Glinde
Tel./Fax: +49-40 73091399-0/-33
info@tribomar.com
Signature



UCHIYAMA VALVE SEISAKUSHO CO.,LTD.
405 NISHITAWARA NABARI-CITY MIE-KEN 518-0609 JAPAN
PHONE: (0595)66-4741 FAX : (0595)66-4751

DATE: 2012.7.1

Supplier's Material Declaration
-Asbestos-

Company name : UCHIYAMA VALVE SEISAKUSHO CO.,LTD.

Hereby declares that our products have not contained asbestos after 1st July 2012 of the delivery/ production date.

Place of issue: MIE JAPAN

Date of issue: 1ST JULY 2012

UCHIYAMA VALVE SEISAKUSHO CO.,LTD.



.....*K. Nagahama*.....

K.Nagahama
The Chief of Quality Control Department

Supplier's Material Declaration

- Asbestos -

Ref.: ish1206115

Company name: VOLCANO Co., Ltd.

Hereby declares that our products have, not contained asbestos after end of August, 2005 of the delivery date.

OSAKA JAPAN

(Place of issue)

06/15/2012

(Date of issue)

TAKASHI KURIMOTO, Director

(Name, function)

T. Kurimoto

(Signature)

Supplier's Material Declaration

- Asbestos -

Ref.: QA12-093

Hereby declares that asbestos is not contained the following product(s) manufactured on or after January 1st, 1992 including spare parts.

Wärtsilä Japan Ltd.
Company name: Seals & Bearings Product Company Japan

Product(s)/Type name;

Stern Tube Seals for Marine Propulsion

Stern Tube Bearings for Marine Propulsion

Intermediate Shaft Bearings for Marine Propulsion

Rudder Seals for Marine Propulsion

Thrust and Journal Bearings

Applicable scope of this promise is the products made by Seals & Bearings Product Company Japan in Wärtsilä Japan Ltd.

14-37, 7-Chome, Mukaishinryo-Machi,
Toyama Japan

(Place of issue)

July 6th, 2012

(Date of issue)

Masaki Mihara
General Manager /Quality

(Name, Title and Department)

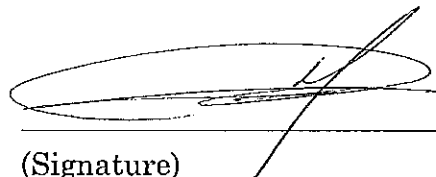

(Signature)

Wilhelmsen Ships Service B.V.

Office:	Willem Barentszstraat 50 3165 AB ROTTERDAM	Telephone:	+31-10-4877777
		Telefax:	+31-10-4877888
Mail:	PO Box 59130 3008 PC ROTTERDAM The Netherlands	E-mail: Internet:	wss.rotterdam@wilhelmsen.com www.wilhelmsen.com/shipservice
		VAT: Chamber of Commerce: Bank:	NL 0013.18.032.B.01 24126823

To whom this may concern

Department: Tech. Prod. Management

Our Ref.: IMO04032015

Your Ref.: --

Date: 04/03/2015

Declaration of the Absence of Asbestos in the Manufacture or Packaging of Materials, Components, Products or Systems.

Wilhelmsen Ships Service B.V. in Rotterdam, The Netherlands being part of Wilhelmsen Ships Service AS in Lysaker, Norway is responsible for the product procurement for all standard products supplied through the WSS network.

The undersigned, recognizing that, in accordance with:

1. International Maritime Organization (IMO) Resolution MSC.282 (86), adopting SOLAS Reg. 11-1/3-5.2, the installation of materials containing asbestos* on all ships (both new construction and existing vessels) is prohibited after 1 January 2011,
2. International Maritime Organization (IMO) Resolution MEPC 197 (62),
3. International Maritime Organization (IMO) and International Association of Classification Societies (IACS), Unified Interpretation UI SC249,

warrants that the afore noted company has not and will not present a material, component, product or system as mentioned in MSC 282, MEPC 197 and UI SC249 containing asbestos* (see attached Annex 1) .

* "asbestos" comprises any of the following six mineral names and associated "Chemical Abstracts Service" (CAS) numbers:

- | | |
|---|------------------|
| 1. Actinolite ($\text{Ca}_2(\text{Mg,Fe})_5\text{Si}_8\text{O}_{22}(\text{OH})_2$) | : CAS 77536-66-4 |
| 2. Amosite (Grunerite) ($(\text{Mg, Fe})_7\text{Si}_8\text{O}_{22}(\text{OH})_2$) | : CAS 12172-73-5 |
| 3. Anthophyllite ($(\text{Mg,Fe})_7\text{Si}_8\text{O}_{22}(\text{OH})_2$) | : CAS 77536-67-5 |
| 4. Chrysotile ($\text{Mg}_3\text{Si}_2\text{O}_5(\text{OH})_4$) | : CAS 12001-29-5 |
| 5. Crocidolite ($\text{Na}_2\text{Fe}/+\text{Fe}_{23}+\text{Si}_8\text{O}_{22}(\text{OH})_2$) | : CAS 12001-28-4 |
| 6. Asbestos Tremolite ($\text{Ca}_2\text{Mg}_5\text{Si}_8\text{O}_{22}(\text{OH})_2$) | : CAS 77536-68-6 |

-- // --



Eddy Scheepers
Sr. Technical Product Manager
Gases, Refrigerants & Cylinders
Business Stream Marine Products
Wilhelmsen Ships Service
Rotterdam, The Netherlands



Leen de Visser
Global HSSE Manager
Business Processes & QHSSE

Wilhelmsen Ships Service
Rotterdam, The Netherlands

SC
249
(cont)

Annex 1

Structure and/or equipment	Component
Propeller shafting	Packing with low pressure hydraulic piping flange Packing with casing Clutch Brake lining Synthetic stern tubes
Diesel engine	Packing with piping flange Lagging material for fuel pipe Lagging material for exhaust pipe Lagging material turbocharger
Turbine engine	Lagging material for casing Packing with flange of piping and valve for steam line, exhaust line and drain line Lagging material for piping and valve of steam line, exhaust line and drain line
Boiler	Insulation in combustion chamber Packing for casing door Lagging material for exhaust pipe Gasket for manhole Gasket for hand hole Gas shield packing for soot blower and other hole Packing with flange of piping and valve for steam line, exhaust line, fuel line and drain line Lagging material for piping and valve of steam line, exhaust line, fuel line and drain line
Exhaust gas economizer	Packing for casing door Packing with manhole Packing with hand hole Gas shield packing for soot blower Packing with flange of piping and valve for steam line, exhaust line, fuel line and drain line Lagging material for piping and valve of steam line, exhaust line, fuel line and drain line
Incinerator	Packing for casing door Packing with manhole Packing with hand hole Lagging material for exhaust pipe
Auxiliary machinery (pump, compressor, oil purifier, crane)	Packing for casing door and valve Gland packing Brake lining
Heat exchanger	Packing with casing Gland packing for valve Lagging material and insulation

SC
249
(cont)

Valve	Gland packing with valve, sheet packing with piping flange Gasket with flange of high pressure and/or high temperature
Pipe, duct	Lagging material and insulation
Tank (fuel tank, hot water, tank, condenser), other equipments (fuel strainer, lubricant oil strainer)	Lagging material and insulation
Electric equipment	Insulation material
Ceiling, floor and wall in accommodation area	Ceiling, floor, wall
Fire door	Packing, construction and insulation of the fire door
Inert gas system	Packing for casing, etc.
Air-conditioning system	Sheet packing, lagging material for piping and flexible joint
Miscellaneous	Ropes Thermal insulating materials Fire shields/fire proofing Space/duct insulation Electrical cable materials Brake linings Floor tiles/deck underlay Steam/water/vent flange gaskets Adhesives/mastics/fillers Sound damping Moulded plastic products Sealing putty Shaft/valve packing Electrical bulkhead penetration packing Circuit breaker arc chutes Pipe hanger inserts Weld shop protectors/burn covers Fire-fighting blankets/clothing/equipment Concrete ballast

The list above is taken from IMO Resolution MEPC.197(62), Appendix 5, paragraph 2.2.2.1.

End of
Document

S/NO: 15



Wilhelmsen Ships Service

Wilhelmsen Ships Service B.V.

Office:	Willem Barentszstraat 50 3165 AB ROTTERDAM	Telephone:	+31-10-4877777
Mail:	PO Box 59130 3008 PC ROTTERDAM The Netherlands	Telefax:	+31-10-4877888
		E-mail:	wss.rotterdam@wilhelmsen.com
		Internet:	www.wilhelmsen.com/shipservice
		VAT:	NL 0013.18.032.B.01
		Chamber of Commerce:	24126823
		Bank:	

To whom this may concern

Department: Tech. Prod. Management

Our Ref.: IMC02072012

Your Ref.: --

Date: 3/07/2012

Declaration of the Absence of Asbestos in the Manufacture or Packaging of Materials, Components, Products or Systems.

Wilhelmsen Ships Service B.V. in Rotterdam, The Netherlands being part of Wilhelmsen Ships Service AS in Lysaker, Norway is responsible for the product procurement for all standard products supplied through the WSS network.

The undersigned, recognizing that, in accordance with:

1. International Maritime Organization (IMO) Resolution MSC.282 (86), adopting SOLAS Reg. 11-1/3-5.2, the installation of materials containing asbestos* on all ships (both new construction and existing vessels) is prohibited after 1 January 2011,
2. International Maritime Organization (IMO) Resolution MEPC 197 (62),
3. International Maritime Organization (IMO) and International Association of Classification Societies (IACS), Unified Interpretation UI SC249,

warrants that the afore noted company has not and will not present a material, component, product or system as mentioned in MSC 282, MEPC 197 and UI SC249 containing asbestos* (see attached Annex 1) .

* "asbestos" comprises any of the following six mineral names and associated "Chemical Abstracts Service" (CAS) numbers:

- | | |
|--|------------------|
| 1. Actinolite ($\text{Ca}_2(\text{Mg,Fe})_5\text{Si}_8\text{O}_{22}(\text{OH})_2$) | : CAS 77536-66-4 |
| 2. Amosite (Grunerite) ($(\text{Mg, Fe})_7\text{Si}_8\text{O}_{22}(\text{OH})_2$) | : CAS 12172-73-5 |
| 3. Anthophyllite ($(\text{Mg,Fe})_7\text{Si}_8\text{O}_{22}(\text{OH})_2$) | : CAS 77536-67-5 |
| 4. Chrysotile ($\text{Mg}_3\text{Si}_2\text{O}_5(\text{OH})_4$) | : CAS 12001-29-5 |
| 5. Crocidolite ($\text{Na}_2\text{Fe}^{+}\text{Fe}_2^{3+}\text{Si}_8\text{O}_{22}(\text{OH})_2$) | : CAS 12001-28-4 |
| 6. Asbestos Tremolite ($\text{Ca}_2\text{Mg}_5\text{Si}_8\text{O}_{22}(\text{OH})_2$) | : CAS 77536-68-6 |

-- // --

Eddy Scheepers
Sr. Technical Product Manager
Gases, Refrigerants & Cylinders
Business Stream Marine Products
Wilhelmsen Ships Service
Rotterdam, The Netherlands



Leen de Visser
Global HSSE Manager
Business Processes & QHSSE

Wilhelmsen Ships Service
Rotterdam, The Netherlands





YAMASHINA SEIKI CO., LTD.

Supplier's Material Declaration

- Asbestos -

Ref.: _____

Company name: YAMASHINA SEIKI CO., LTD. _____

Hereby declares that our products have not contained asbestos after 18/JAN./2006 of the production date.

/525, Higashisaka, Ritto, Shiga Prefecture
Zip 520-3001

27 / JUN. / 2012

(Place of issue)

(Date of issue)

General Manager Heat Exchanger
Division K. YAMASHITA

山下耕三

(Name, function)

(Signature)

YAMASHINA SEIKI CO., LTD.

Head Office 525 Higashisaka Ritto-cho Kurita-gun Shiga Japan 520-30
Mail Address yasec@mx.biwa.or.jp

Osaka Office 1-35 Kansenhigashi build 1chome Nishiawaji Higashiyodogawa-ku Osaka Japan 533

Tokyo Office 17 Hoeikonyacho build Kanda Konya-cho Chiyoda-ku Tokyo Japan 101

Tel 0775-58-2311 Fax 0775-58-2319

Int +81-775-58-2311 Int +81-775-58-2319

Tel 06-325-1201 Fax 06-325-1207

Int +81-6-325-1201 Int +81-6-325-1207

Tel 03-3256-6751 Fax 03-3256-6756

Int +81-3-3256-6751 Int +81-3-3256-6756

2012.5

Supplier's Material Declaration

- Asbestos -

Ref.: YAQ-QC-12-08

Company name: YANMAR Co, LTD. Large Power Products Operations Div.

Hereby declares that our products and spare parts have not contained asbestos after 30/09/2004 of the delivery date.

1-1-1, Nagasuhigashidori Amagasaki,
Hyogo, 660-8585, JAPAN

01/July/2012

(Place of issue)

(Date of issue)

Yasuhiro Kanai
Senior Manager, Quality Control Dept.



(Name, function)

(Signature)

Yokogawa Denshikiki Co., Ltd.
1-15-8 Kami-iioaka, Morioka,
Iwate 020-0854 Japan
Phone : 81-19-638-5211
Facsimile : 81-19-637-1015



Date : July 5, 2012

Ref. No. : YDK-D02-AA-12-912

Supplier's Material Declaration - Asbestos -

We Yokogawa Denshikiki Co., Ltd. hereby declares that our all products, spare parts and supplies have not contained asbestos after August 10, 2005 of the delivery date.

Place of Issue

1-15-8 Kami-iioaka, Morioka,
Iwate 020-0854 Japan

Date of Issue

July 5, 2012



Susumu Kumagai,
General Manager
Quality Assurance Department